

<b>UF4003GP ... UF4007GP</b> <b>Ultrafast Recovery Rectifier Diodes</b> <b>Gleichrichterioden mit ultraschnellem Sperrverzug</b>	<b>I<sub>FAV</sub> = 1 A</b> <b>V<sub>F</sub> &lt; 1.0...1.7 V</b> <b>T<sub>jmax</sub> = 175°C</b>	<b>V<sub>RRM</sub> = 200...1000 V</b> <b>I<sub>FSM</sub> = 30/33 A</b> <b>t<sub>rr</sub> &lt; 50...75 ns</b>
--	--	--

Version 2018-12-14

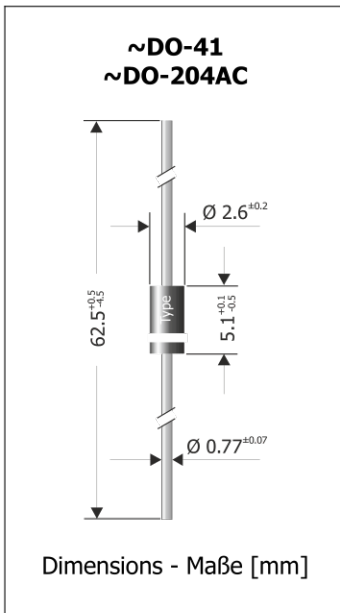

**Typical Applications**

Rectification of higher frequencies  
 High speed switching  
 Commercial grade  
 Suffix -Q: AEC-Q101 compliant <sup>1)</sup>  
 Suffix -AQ: in AEC-Q101 qualification <sup>1)</sup>

**Features**

Glass passivated junction  
 Very low reverse recovery time  
 Compliant to RoHS, REACH,  
 Conflict Minerals <sup>1)</sup>

**Mechanical Data <sup>1)</sup>**

Taped in ammo pack  
 Weight approx.  
 Case material  
 Solder & assembly conditions

**Typische Anwendungen**

Gleichrichtung hoher Frequenzen  
 Schnelles Schalten  
 Standardausführung  
 Suffix -Q: AEC-Q101 konform <sup>1)</sup>  
 Suffix -AQ: in AEC-Q101 Qualifikation <sup>1)</sup>

**Besonderheiten**

Glaspassivierte Sperrschicht  
 Sehr niedrige Sperrverzugszeit  
 Konform zu RoHS, REACH,  
 Konfliktmineralien <sup>1)</sup>

**Mechanische Daten <sup>1)</sup>**



5000	Gegurtet in Ammo-Pack
0.4 g	Gewicht ca.
UL 94V-0	Gehäusematerial
260°C/10s	Löt- und Einbaubedingungen
MSL N/A	

**Maximum ratings <sup>2)</sup>**

**Grenzwerte <sup>2)</sup>**

Type Typ	Repetitive peak reverse voltage Periodische Spitzensperrspannung V <sub>RRM</sub> [V]	Surge peak reverse voltage Stoßspitzensperrspannung V <sub>RSM</sub> [V]
UF4003GP	200	200
UF4004GP	400	400
UF4005GP	600	600
UF4006GP	800	800
UF4007GP	1000	1000

Max. average forward rectified current, R-load Dauerstrom in Einwegschaltung mit R-Last	T <sub>A</sub> = 50°C	I <sub>FAV</sub>	1 A <sup>3)</sup>
Repetitive peak forward current Periodischer Spitzenstrom	f > 15 Hz	T <sub>A</sub> = 50°C	I <sub>FRM</sub> 10 A <sup>3)</sup>
Peak forward surge current Stoßstrom in Fluss-Richtung	Half sine-wave Sinus-Halbwellen	50 Hz (10 ms) 60 Hz (8.3 ms)	I <sub>FSM</sub> 30 A 33 A
Rating for fusing – Grenzlastintegral	t < 10 ms	i <sup>2</sup> t	4.5 A <sup>2</sup> s
Junction temperature – Sperrschichttemperatur Storage temperature – Lagerungstemperatur		T <sub>j</sub> T <sub>s</sub>	-50...+175°C -50...+175°C

1 Please note the [detailed information on our website](#) or at the beginning of the data book  
 Bitte beachten Sie die [detaillierten Hinweise auf unserer Internetseite](#) bzw. am Anfang des Datenbuches  
 2 T<sub>A</sub> = 25°C unless otherwise specified – T<sub>A</sub> = 25°C wenn nicht anders angegeben  
 3 Valid, if leads are kept at ambient temperature at a distance of 10 mm from case  
 Gültig, wenn die Anschlussdrähte in 10 mm Abstand von Gehäuse auf Umgebungstemperatur gehalten werden

**Characteristics**
**Kennwerte**

Type Typ	Reverse recovery time Sperrverzugszeit	Forward voltage Durchlass-Spannung
	$T_j = 25^\circ\text{C}$	$V_F$ [V] at / bei $I_F$ [A]
UF4003GP	$t_{rr}$ [ns] <sup>1)</sup> < 50	< 1.0 1
UF4004GP	< 50	< 1.25 1
UF4005GP ... UF4007GP	< 75	< 1.7 1

Leakage current Sperrstrom	$T_j = 25^\circ\text{C}$ $T_j = 100^\circ\text{C}$	$V_R = V_{RRM}$	$I_R$	< 5 $\mu\text{A}$ < 50 $\mu\text{A}$
Typical junction capacitance Typische Sperrschichtkapazität		$V_R = 4\text{ V}$	$C_j$	17 pF
Typical thermal resistance junction to ambient Typischer Wärmewiderstand Sperrschicht – Umgebung			$R_{thA}$	45 K/W <sup>2)</sup>
Typical thermal resistance junction to leads Typischer Wärmewiderstand Sperrschicht – Anschlussdraht			$R_{thL}$	15 K/W

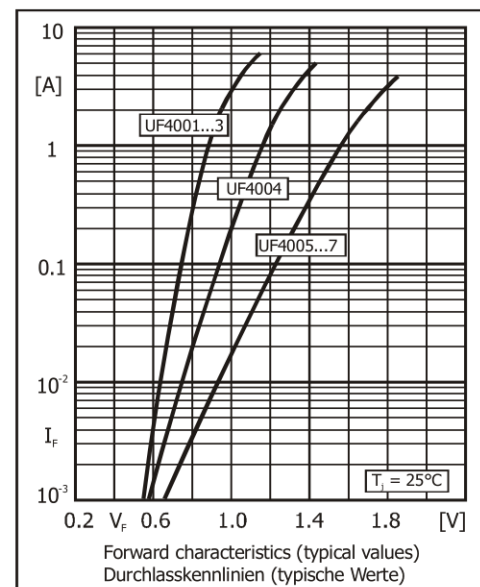
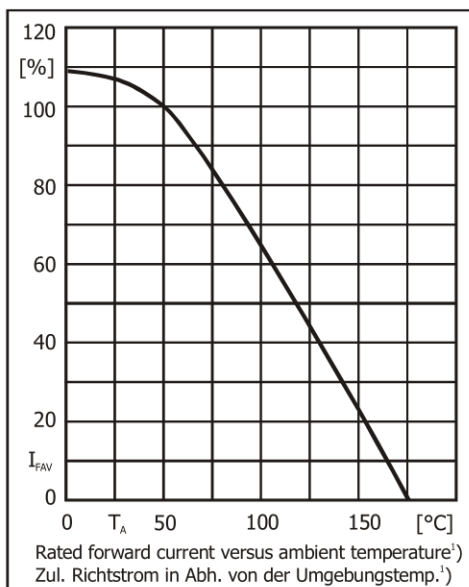

**Disclaimer:** See data book page 2 or [website](#)  
**Haftungsausschluss:** Siehe Datenbuch Seite 2 oder [Internet](#)

- $I_F = 0.5\text{ A}$  through/über  $I_R = 1\text{ A}$  to/auf  $I_R = 0.25\text{ A}$
- Valid, if leads are kept at ambient temperature at a distance of 10 mm from case  
 Gültig, wenn die Anschlussdrähte in 10 mm Abstand vom Gehäuse auf Umgebungstemperatur gehalten werden