

16F120 series standard recovery diodes

1

Features

- Hermetic metal case with ceramic insulator
- Capacity of supporting High surge current
- Stud cathode and stud anode version

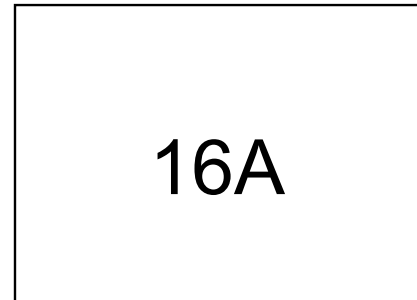

Typical Applications

- Converters
- Power supplies
- Machine tool controls

Major Ratings and Characteristics

Parameters		16F120	Units
I _{F(AV)}		16	A
	@ T _{hs}	120	°C
I _{F(RMS)}		25	A
I _{FSM}	@ 50Hz	356	A
	@ 60Hz	373	A
I ² t	@ 50Hz	636	A ² s
	@ 60Hz	580	A ² s
V _{RRM}	range	600 to 1200	V
T _J	range	-65 to 175	°C

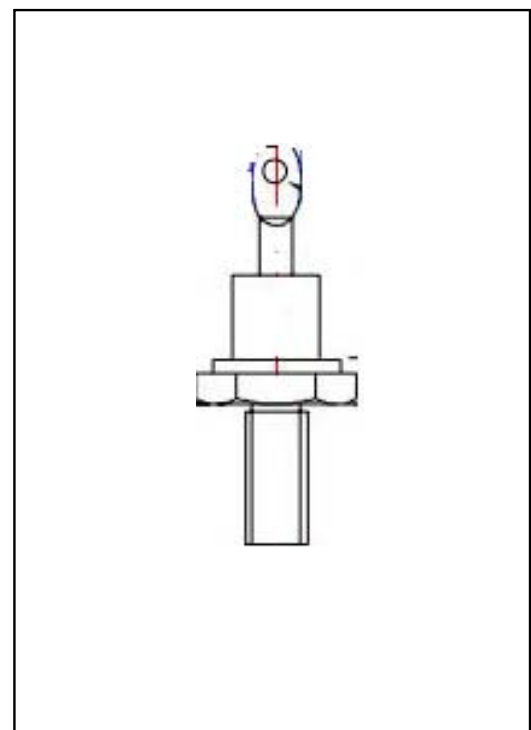

ELECTRICAL SPECIFICATIONS

Voltage Ratings

16F120	Voltage Code	V_{RRM} , maximum repetitive peak reverse voltage V	V_{RSM} , maximum non-repetitive peak rev. voltage V	I_{RRM} max. @ $T_J = 175^\circ\text{C}$ mA
	10	1000	1100	12
	16	1600	1700	

Forward Conduction

Parameter	16F	Units	Conditions		
$I_{F(AV)}$ Max. average forward current @ Heatsink temperature	16	A	180° conduction, half sine wave		
	120	°C	Double side (single side) cooled		
$I_{F(RMS)}$ Max.RMS forward current	25	A			
I_{FSM} Max. peak, one-cycle forward, non-repetitive surge current	356	A	t = 10ms	No voltage reappplied	Sinusoidal half wave, Initial $T_J = T_{J \text{ max}}$
	373		t = 8.3ms	reappplied	
	300		t = 10ms	100% V_{RRM}	
	314		t = 8.3ms	reappplied	
$I^2 t$ Maximum $I^2 t$ for fusing	636	$A^2 s$	t = 10ms	No voltage reappplied	
	580		t = 8.3ms	reappplied	
	450		t = 10ms	100% V_{RRM}	
	410		t = 8.3ms	reappplied	
$I^2 \sqrt{t}$ Maximum $I^2 \sqrt{t}$ for fusing	6360	$A^2 \sqrt{s}$	t = 0.1 to 10ms, no voltage reappplied		
V_{FM} Max. forward voltage drop	1.30	V	$I_{pk} = 78A, T_J = 25^\circ\text{C}, t_p = 400 \mu s$ rectangular wave		
$V_{F(TO)}$ Low level value of threshold voltage	0.8	V	$(16.7\% \times \pi \times I_{F(AV)} < 1 < \pi \times I_{F(AV)})$, $T_J = T_{J \text{ max}}$		
r_f Low level value of forward slope resistance	6.8	MΩ	$(16.7\% \times \pi \times I_{F(AV)} < 1 < \pi \times I_{F(AV)})$, $T_J = T_{J \text{ max}}$		

Thermal and Mechanical Specification

Parameter	16F120	Units	Conditions
T_J Max.junction operating temperature range	-65 to 175	°C	
T_{stg} Max. storage temperature range	-65 to 200		
R_{thJC} Max,thermal resistance,junction to case	1.5	K/W	DC operation
R_{thCS} Max. thermal resistance,Case to heatsink	0.5		Mounting surface,smooth,flatand greased
T Max.allowed Mounting torque, ± 10%	7	N	
wt Approximate weight	11	g	

1

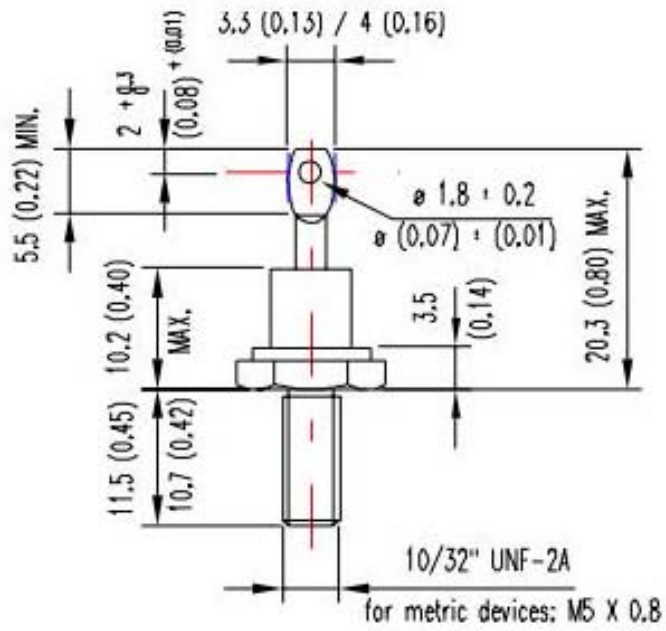

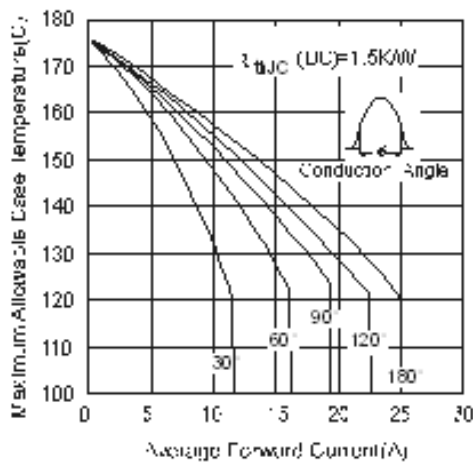

Fig.1-Current Ratings Characteristics

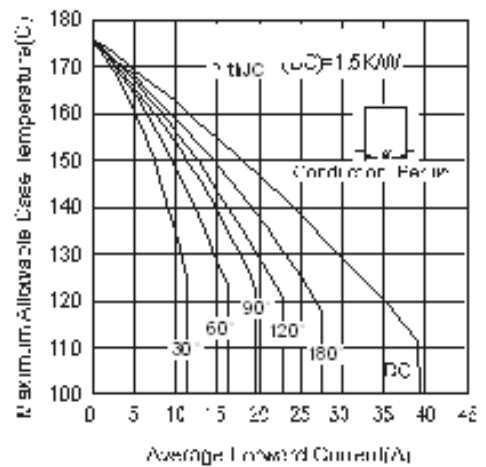

Fig.2-Current Ratings Characteristics

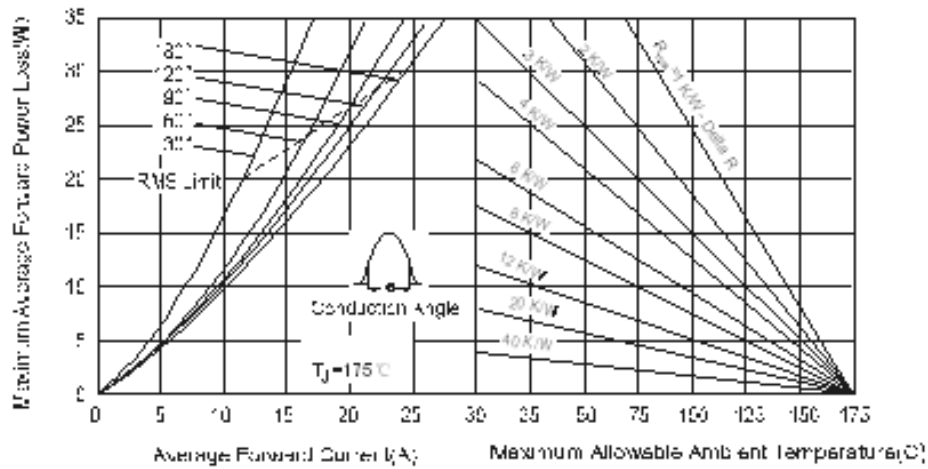

Fig.3-Forward Power Loss Characteristics

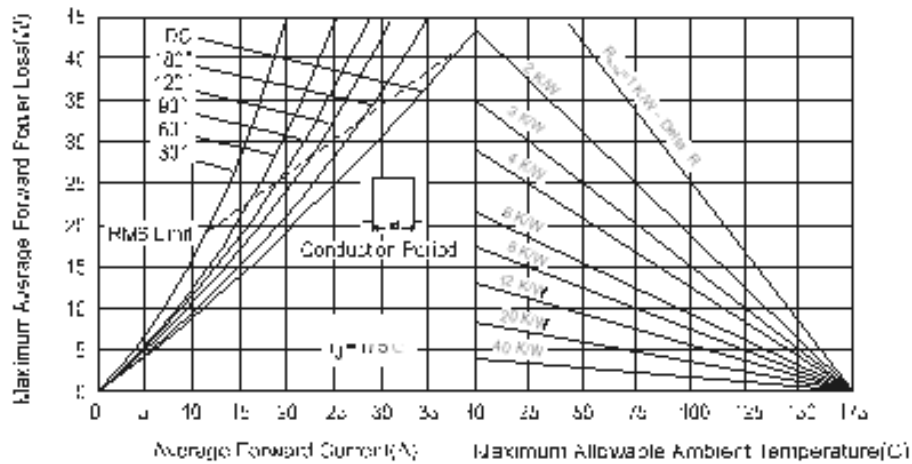

Fig.1-Forward Power Loss Characteristics

1

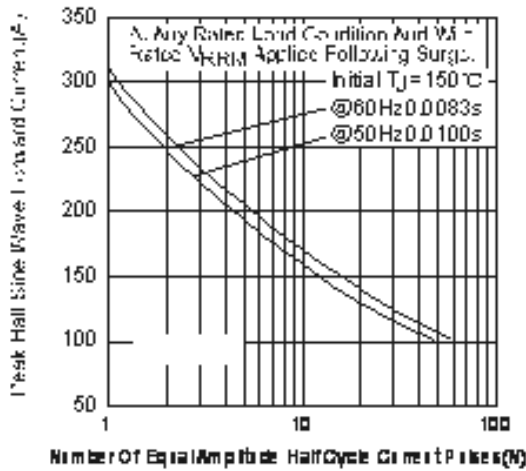

Fig.5-Maximum Non-Repetitive Surge Current

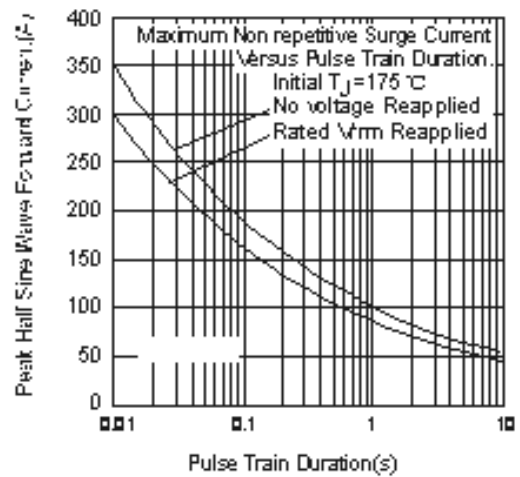

Fig.6-Maximum Non-Repetitive Surge Current

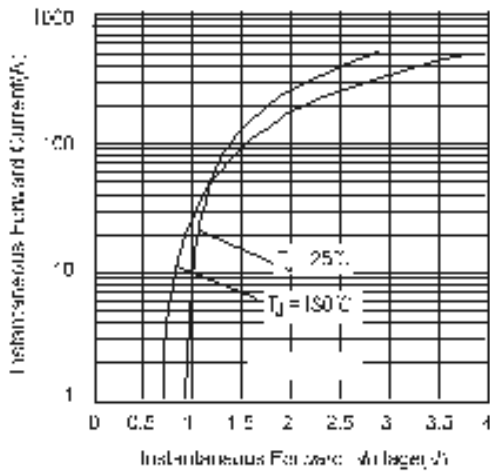

Fig.7-Forward Voltage Drop Characteristics

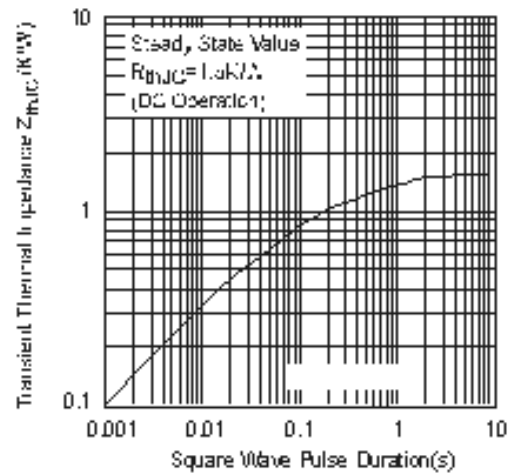

Fig.8-Thermal Impedance Z_{th(jc)} Characteristics