

Thyristor Modules

Thyristor/Diode Modules

$I_{TRMS} = 2 \times 100 \text{ A}$
 $I_{TAVM} = 2 \times 64 \text{ A}$
 $V_{RRM} = 800-1800 \text{ V}$

TO-240 AA

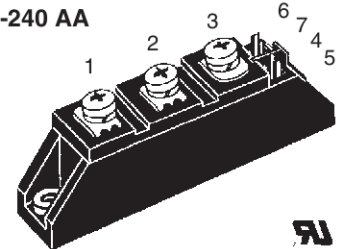

V_{RSM}	V_{RRM}	Type					
V_{DSM}	V_{DRM}	Version			Version		
V	V	1 B	8 B	1 B	8 B	1 B	8 B
900	800	MCC 56-08	io1 B / io8 B	MCD 56-08	io1 B / io8 B		
1300	1200	MCC 56-12	io1 B / io8 B	MCD 56-12	io1 B / io8 B		
1500	1400	MCC 56-14	io1 B / io8 B	MCD 56-14	io1 B / io8 B		
1700	1600	MCC 56-16	io1 B / io8 B	MCD 56-16	io1 B / io8 B		
1900	1800	MCC 56-18	io1 B / io8 B	MCD 56-18	io1 B / io8 B		

Symbol	Conditions	Maximum Ratings	
I_{TRMS}, I_{FRMS}	$T_{VJ} = T_{VJM}$	100	A
I_{TAVM}, I_{FAVM}	$T_C = 83^\circ\text{C}; 180^\circ \text{ sine}$	64	A
	$T_C = 85^\circ\text{C}; 180^\circ \text{ sine}$	60	A
I_{TSM}, I_{FSM}	$T_{VJ} = 45^\circ\text{C};$ $V_R = 0$	t = 10 ms (50 Hz), sine t = 8.3 ms (60 Hz), sine	1500 A 1600 A
	$T_{VJ} = T_{VJM}$ $V_R = 0$	t = 10 ms (50 Hz), sine t = 8.3 ms (60 Hz), sine	1350 A 1450 A
$\int i^2 dt$	$T_{VJ} = 45^\circ\text{C}$ $V_R = 0$	t = 10 ms (50 Hz), sine t = 8.3 ms (60 Hz), sine	11 200 A ² s 10 750 A ² s
	$T_{VJ} = T_{VJM}$ $V_R = 0$	t = 10 ms (50 Hz), sine t = 8.3 ms (60 Hz), sine	9100 A ² s 8830 A ² s
$(di/dt)_{cr}$	$T_{VJ} = T_{VJM}$ f = 50 Hz, $t_p = 200 \mu\text{s}$ $V_D = \frac{2}{3} V_{DRM}$	repetitive, $I_T = 150 \text{ A}$	150 A/ μs
	$I_G = 0.45 \text{ A}$ $di_G/dt = 0.45 \text{ A}/\mu\text{s}$	non repetitive, $I_T = I_{TAVM}$	500 A/ μs
$(dv/dt)_{cr}$	$T_{VJ} = T_{VJM};$ $R_{GK} = \infty;$ method 1 (linear voltage rise)	$V_{DR} = \frac{2}{3} V_{DRM}$	1000 V/ μs
P_{GM}	$T_{VJ} = T_{VJM};$ $I_T = I_{TAVM};$	$t_p = 30 \mu\text{s}$ $t_p = 300 \mu\text{s}$	10 W 5 W
P_{GAV}			0.5 W
V_{RGM}			10 V
T_{VJ}			-40...+125 °C
T_{VJM}			125 °C
T_{stg}			-40...+125 °C
V_{ISOL}	50/60 Hz, RMS; $I_{ISOL} \leq 1 \text{ mA};$	t = 1 min t = 1 s	3000 V~ 3600 V~
M_d	Mounting torque (M5) Terminal connection torque (M5)		2.5-4.0/22-35 Nm/lb.in. 2.5-4.0/22-35 Nm/lb.in.
Weight	Typical including screws		90 g

Data according to IEC 60747 and refer to a single thyristor/diode unless otherwise stated. IXYS reserves the right to change limits, test conditions and dimensions

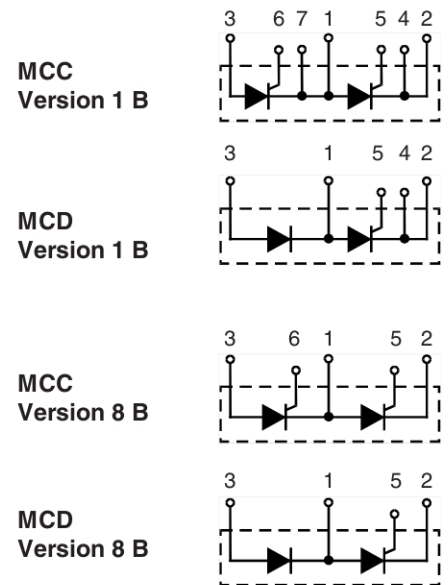

Features

- International standard package, JEDEC TO-240 AA
- Direct copper bonded Al_2O_3 -ceramic base plate
- Planar passivated chips
- Isolation voltage 3600 V~
- UL registered, E 72873
- Gate-cathode twin pins for version 1B

Applications

- DC motor control
- Softstart AC motor controller
- Light, heat and temperature control

Advantages

- Space and weight savings
- Simple mounting with two screws
- Improved temperature and power cycling
- Reduced protection circuits

Symbol	Conditions	Characteristic Values	
I_{RRM}, I_{DRM}	$T_{VJ} = T_{VJM}; V_R = V_{RRM}; V_D = V_{DRM}$	5	mA
V_T, V_F	$I_T/I_F = 200 \text{ A}; T_{VJ} = 25^\circ\text{C}$	1.57	V
V_{T0}	For power-loss calculations only ($T_{VJ} = 125^\circ\text{C}$)	0.85	V
r_T		3.7	m Ω
V_{GT}	$V_D = 6 \text{ V}; T_{VJ} = 25^\circ\text{C}$	1.5	V
	$T_{VJ} = -40^\circ\text{C}$	1.6	V
I_{GT}	$V_D = 6 \text{ V}; T_{VJ} = 25^\circ\text{C}$	100	mA
	$T_{VJ} = -40^\circ\text{C}$	200	mA
V_{GD}	$T_{VJ} = T_{VJM}; V_D = 2/3 V_{DRM}$	0.2	V
I_{GD}		10	mA
I_L	$T_{VJ} = 25^\circ\text{C}; t_p = 10 \mu\text{s}; V_D = 6 \text{ V}$ $I_G = 0.45 \text{ A}; di_G/dt = 0.45 \text{ A}/\mu\text{s}$	450	mA
I_H	$T_{VJ} = 25^\circ\text{C}; V_D = 6 \text{ V}; R_{GK} = \infty$	200	mA
t_{gd}	$T_{VJ} = 25^\circ\text{C}; V_D = 1/2 V_{DRM}$ $I_G = 0.45 \text{ A}; di_G/dt = 0.45 \text{ A}/\mu\text{s}$	2	μs
t_q	$T_{VJ} = T_{VJM}; I_T = 150 \text{ A}, t_p = 200 \mu\text{s}; -di/dt = 10 \text{ A}/\mu\text{s}$ $V_R = 100 \text{ V}; dv/dt = 20 \text{ V}/\mu\text{s}; V_D = 2/3 V_{DRM}$	typ. 150	μs
Q_S	$T_{VJ} = T_{VJM}; I_T, I_F = 50 \text{ A}, -di/dt = 3 \text{ A}/\mu\text{s}$	100	μC
I_{RM}		24	A
R_{thJC}	per thyristor/diode; DC current per module	0.45	K/W
R_{thJK}	per thyristor/diode; DC current per module	0.225	K/W
	other values see Fig. 8/9	0.65	K/W
		0.325	K/W
d_s	Creepage distance on surface	12.7	mm
d_A	Strike distance through air	9.6	mm
a	Maximum allowable acceleration	50	m/s ²

Optional accessories for module-type MCC 56 version 1 B
 Keyed gate/cathode twin plugs with wire length = 350 mm, gate = yellow, cathode = red
 Type **ZY 200L** (L = Left for pin pair 4/5) } UL 758, style 1385,
 Type **ZY 200R** (R = right for pin pair 6/7) } CSA class 5851, guide 460-1-1

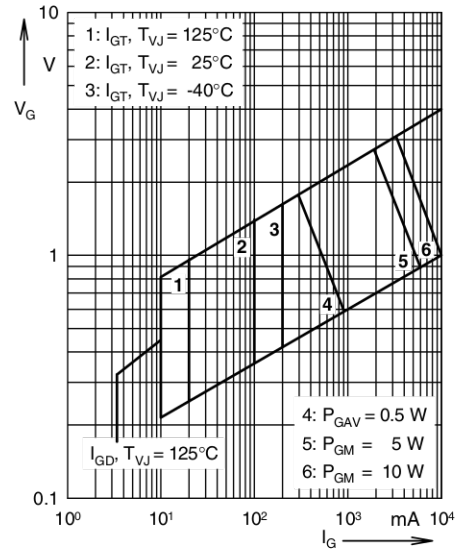

Fig. 1 Gate trigger characteristics

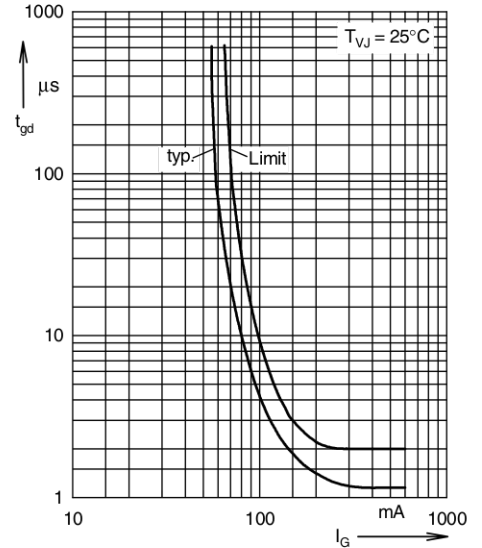
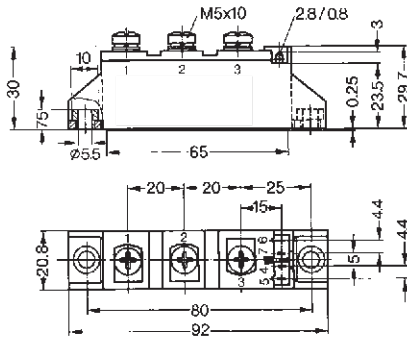

Fig. 2 Gate trigger delay time

Dimensions in mm (1 mm = 0.0394")

MCC / MCD / MDC Version 1 B



MCC Version 8 B

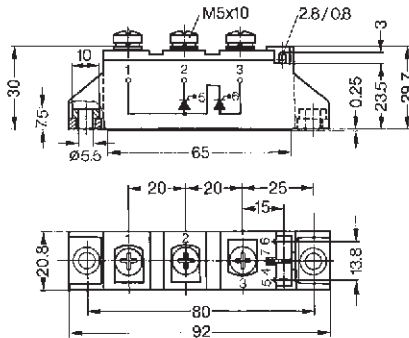

MCD Version 8 B

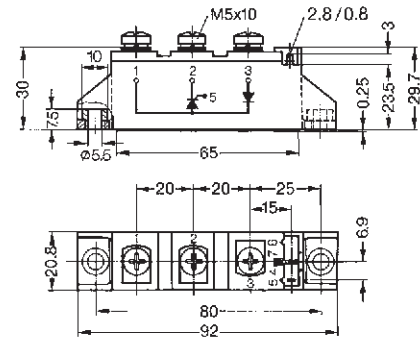

Version 1 or 8 without B in typ designation = without insert in mountg holes

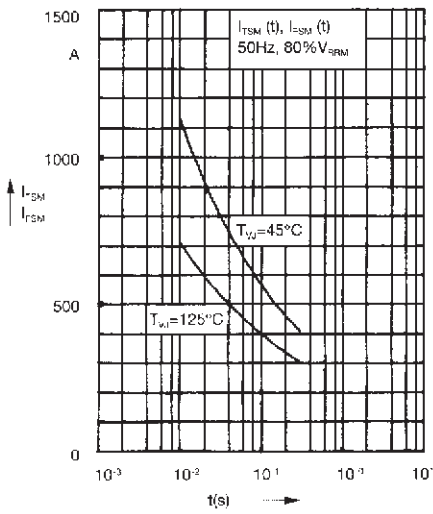

Fig. 3 Surge overload current
 I_{TSM} , I_{FSM} : Crest value, t : duration

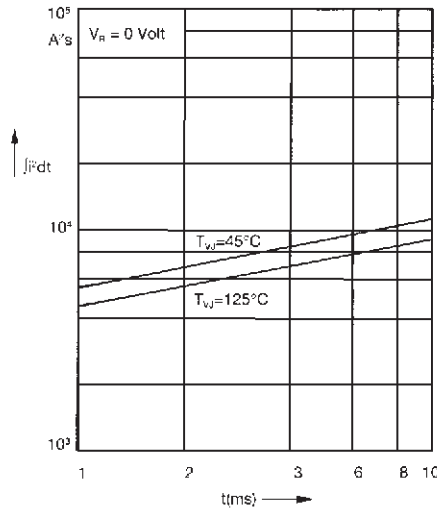

Fig. 4 $\int i^2 dt$ versus time (1-10 ms)

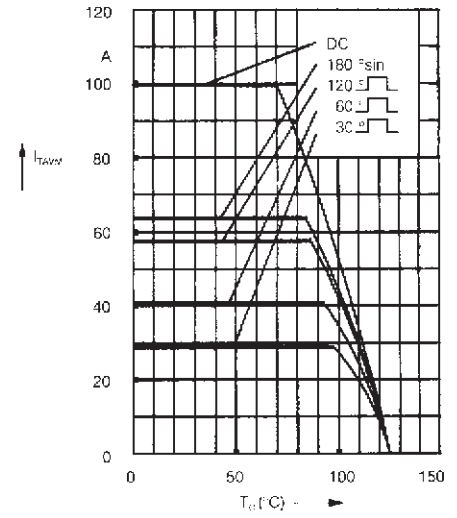

Fig. 4a Maximum forward current at case temperature

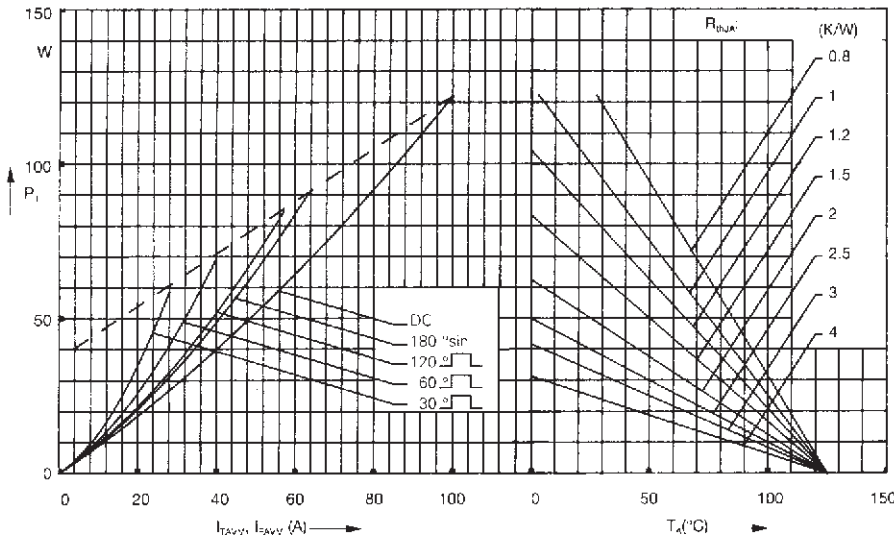

Fig. 5 Power dissipation versus on-state current and ambient temperature (per thyristor or diode)

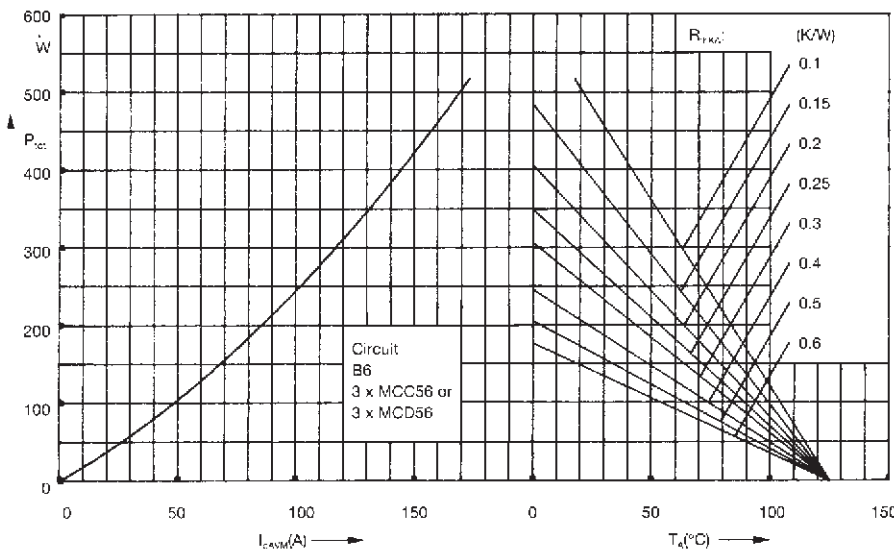

Fig. 6 Three phase rectifier bridge: Power dissipation versus direct output current and ambient temperature

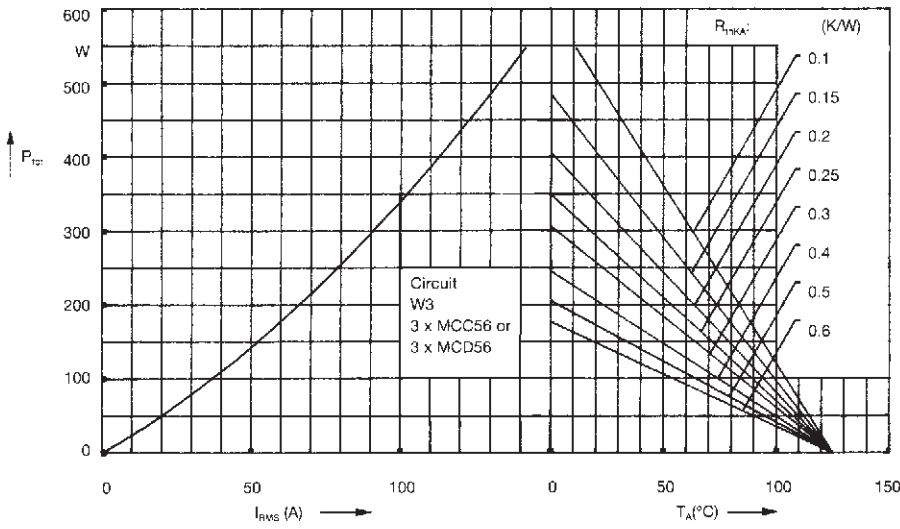

Fig. 7 Three phase AC-controller:
Power dissipation versus RMS
output current and ambient
temperature

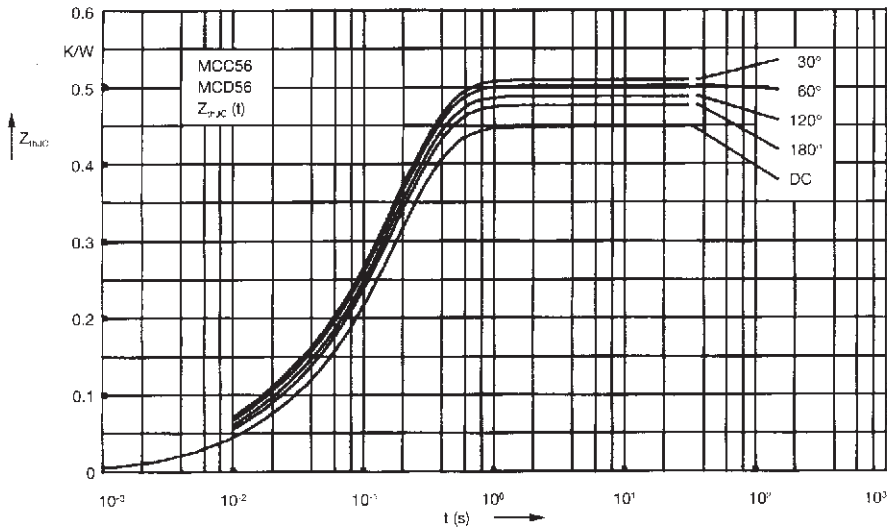

Fig. 8 Transient thermal impedance
junction to case (per thyristor or
diode)

$R_{\theta JC}$ for various conduction angles d:

d	$R_{\theta JC}$ (K/W)
DC	0.45
180°	0.47
120°	0.49
60°	0.505
30°	0.52

Constants for $Z_{\theta JC}$ calculation:

i	$R_{\theta i}$ (K/W)	t_i (s)
1	0.014	0.015
2	0.026	0.0095
3	0.41	0.175

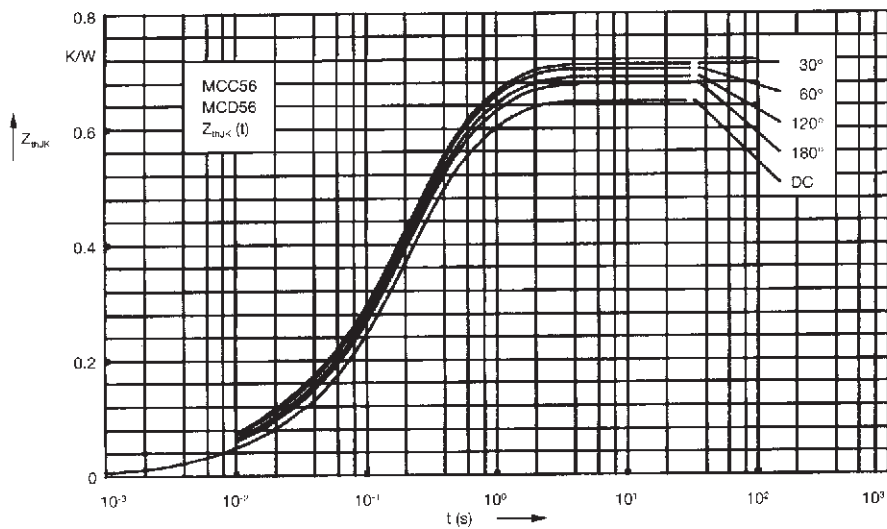

Fig. 9 Transient thermal impedance
junction to heatsink (per thyristor
or diode)

$R_{\theta JK}$ for various conduction angles d:

d	$R_{\theta JK}$ (K/W)
DC	0.65
180°	0.67
120°	0.69
60°	0.705
30°	0.72

Constants for $Z_{\theta JK}$ calculation:

i	$R_{\theta i}$ (K/W)	t_i (s)
1	0.014	0.015
2	0.026	0.0095
3	0.41	0.175
4	0.2	0.67