

Thyristor \ Diode Module

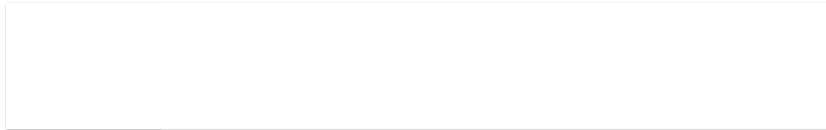

Phase leg

$$V_{RRM} = 2 \times 1600 \text{ V}$$

$$I_{TAV} = 216 \text{ A}$$

$$V_T = 1.1 \text{ V}$$

Part number

MCD200-16io1

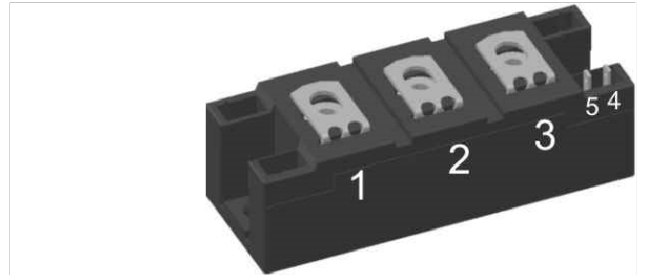

Backside: isolated

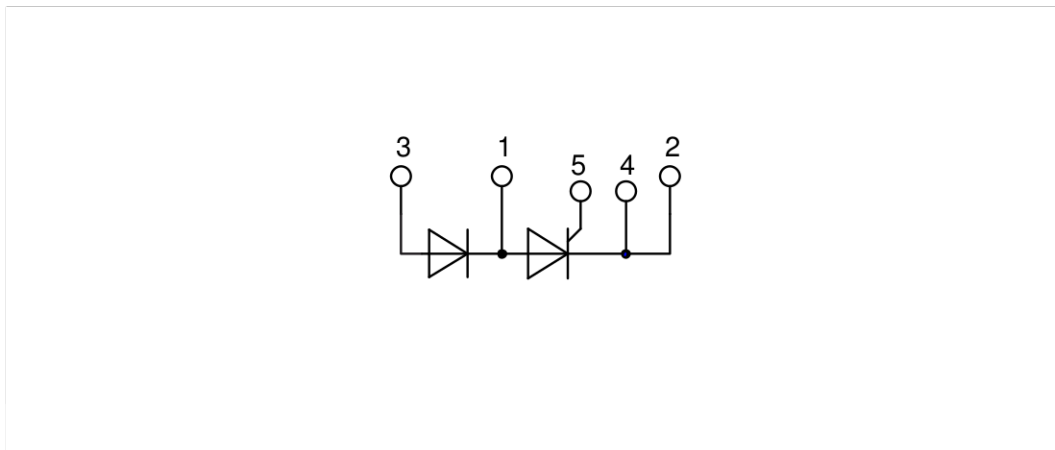

Features / Advantages:

- Thyristor for line frequency
- Planar passivated chip
- Long-term stability
- Direct Copper Bonded Al₂O₃-ceramic

Applications:

- Line rectifying 50/60 Hz
- Softstart AC motor control
- DC Motor control
- Power converter
- AC power control
- Lighting and temperature control

Package: Y4

- Isolation Voltage: 3600 V~
- Industry standard outline
- RoHS compliant
- Soldering pins for PCB mounting
- Base plate: DCB ceramic
- Reduced weight
- Advanced power cycling

Terms Conditions of usage:

The data contained in this product data sheet is exclusively intended for technically trained staff. The user will have to evaluate the suitability of the product for the intended application and the completeness of the product data with respect to his application. The specifications of our components may not be considered as an assurance of component characteristics. The information in the valid application- and assembly notes must be considered. Should you require product information in excess of the data given in this product data sheet or which concerns the specific application of your product, please contact the sales office, which is responsible for you.

Due to technical requirements our product may contain dangerous substances. For information on the types in question please contact the sales office, which is responsible for you. Should you intend to use the product in aviation, in health or live endangering or life support applications, please notify. For any such application we urgently recommend

- to perform joint risk and quality assessments;

- the conclusion of quality agreements;

- to establish joint measures of an ongoing product survey, and that we may make delivery dependent on the realization of any such measures.

Rectifier				Ratings			
Symbol	Definition	Conditions	min.	typ.	max.	Unit	
$V_{RSM/DSM}$	max. non-repetitive reverse/forward blocking voltage				1700	V	
$V_{RRM/DRM}$	max. repetitive reverse/forward blocking voltage				1600	V	
I_{RD}	reverse current, drain current	$V_{RD} = 1600$ V	$T_{VJ} = 25^{\circ}\text{C}$		400	μA	
		$V_{RD} = 1600$ V	$T_{VJ} = 125^{\circ}\text{C}$		15	mA	
V_T	forward voltage drop	$I_T = 200$ A	$T_{VJ} = 25^{\circ}\text{C}$		1.20	V	
		$I_T = 400$ A			1.52	V	
		$I_T = 200$ A	$T_{VJ} = 125^{\circ}\text{C}$		1.10	V	
		$I_T = 400$ A			1.50	V	
I_{TAV}	average forward current	$T_C = 85^{\circ}\text{C}$	$T_{VJ} = 125^{\circ}\text{C}$		216	A	
$I_{T(RMS)}$	RMS forward current	180° sine			340	A	
V_{T0}	threshold voltage	} for power loss calculation only	$T_{VJ} = 125^{\circ}\text{C}$		0.80	V	
r_T	slope resistance				1.4	m Ω	
R_{thJC}	thermal resistance junction to case				0.13	K/W	
R_{thCH}	thermal resistance case to heatsink			0.05		K/W	
P_{tot}	total power dissipation		$T_C = 25^{\circ}\text{C}$		770	W	
I_{TSM}	max. forward surge current	$t = 10$ ms; (50 Hz), sine	$T_{VJ} = 45^{\circ}\text{C}$		8.00	kA	
		$t = 8,3$ ms; (60 Hz), sine	$V_R = 0$ V		8.64	kA	
		$t = 10$ ms; (50 Hz), sine	$T_{VJ} = 125^{\circ}\text{C}$		6.80	kA	
		$t = 8,3$ ms; (60 Hz), sine	$V_R = 0$ V		7.35	kA	
I^2t	value for fusing	$t = 10$ ms; (50 Hz), sine	$T_{VJ} = 45^{\circ}\text{C}$		320.0	kA ² s	
		$t = 8,3$ ms; (60 Hz), sine	$V_R = 0$ V		310.5	kA ² s	
		$t = 10$ ms; (50 Hz), sine	$T_{VJ} = 125^{\circ}\text{C}$		231.2	kA ² s	
		$t = 8,3$ ms; (60 Hz), sine	$V_R = 0$ V		224.4	kA ² s	
C_J	junction capacitance	$V_R = 400$ V $f = 1$ MHz	$T_{VJ} = 25^{\circ}\text{C}$	366		pF	
P_{GM}	max. gate power dissipation	$t_p = 30$ μs	$T_C = 125^{\circ}\text{C}$		120	W	
		$t_p = 500$ μs			60	W	
P_{GAV}	average gate power dissipation				20	W	
$(di/dt)_{cr}$	critical rate of rise of current	$T_{VJ} = 125^{\circ}\text{C}; f = 50$ Hz	repetitive, $I_T = 600$ A		100	A/ μs	
		$t_p = 200$ $\mu\text{s}; di_G/dt = 0.5$ A/ μs ;	non-repet., $I_T = 200$ A		500	A/ μs	
$(dv/dt)_{cr}$	critical rate of rise of voltage	$V = \frac{2}{3} V_{DRM}$	$T_{VJ} = 125^{\circ}\text{C}$		1000	V/ μs	
		$R_{GK} = \infty$; method 1 (linear voltage rise)					
V_{GT}	gate trigger voltage	$V_D = 6$ V	$T_{VJ} = 25^{\circ}\text{C}$		2	V	
			$T_{VJ} = -40^{\circ}\text{C}$		3	V	
I_{GT}	gate trigger current	$V_D = 6$ V	$T_{VJ} = 25^{\circ}\text{C}$		150	mA	
			$T_{VJ} = -40^{\circ}\text{C}$		220	mA	
V_{GD}	gate non-trigger voltage	$V_D = \frac{2}{3} V_{DRM}$	$T_{VJ} = 125^{\circ}\text{C}$		0.25	V	
I_{GD}	gate non-trigger current				10	mA	
I_L	latching current	$t_p = 30$ μs	$T_{VJ} = 25^{\circ}\text{C}$		200	mA	
		$I_G = 0.5$ A; $di_G/dt = 0.5$ A/ μs					
I_H	holding current	$V_D = 6$ V $R_{GK} = \infty$	$T_{VJ} = 25^{\circ}\text{C}$		150	mA	
t_{gd}	gate controlled delay time	$V_D = \frac{1}{2} V_{DRM}$	$T_{VJ} = 25^{\circ}\text{C}$		2	μs	
		$I_G = 0.5$ A; $di_G/dt = 0.5$ A/ μs					
t_q	turn-off time	$V_R = 100$ V; $I_T = 300$ A; $V = \frac{2}{3} V_{DRM}$	$T_{VJ} = 100^{\circ}\text{C}$	200		μs	
		$di/dt = 10$ A/ μs $dv/dt = 50$ V/ μs $t_p = 200$ μs					

Package Y4				Ratings		
Symbol	Definition	Conditions	min.	typ.	max.	Unit
I_{RMS}	RMS current	per terminal			300	A
T_{VJ}	virtual junction temperature		-40		125	°C
T_{op}	operation temperature		-40		100	°C
T_{stg}	storage temperature		-40		125	°C
Weight					150	g
M_D	mounting torque		2.25		2.75	Nm
M_T	terminal torque		4.5		5.5	Nm
$d_{Spp/APP}$	creepage distance on surface striking distance through air	terminal to terminal	14.0	10.0		mm
$d_{Spb/APb}$		terminal to backside	16.0	16.0		mm
V_{ISOL}	isolation voltage	t = 1 second		3600		V
		t = 1 minute	50/60 Hz, RMS; $I_{ISOL} \leq 1$ mA	3000		V

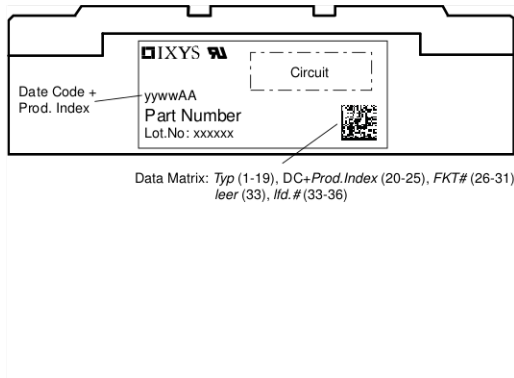

Ordering	Ordering Number	Marking on Product	Delivery Mode	Quantity	Code No.
Standard	MCD200-16io1	MCD200-16io1	Box	6	498269

Equivalent Circuits for Simulation * on die level $T_{VJ} = 125^\circ\text{C}$

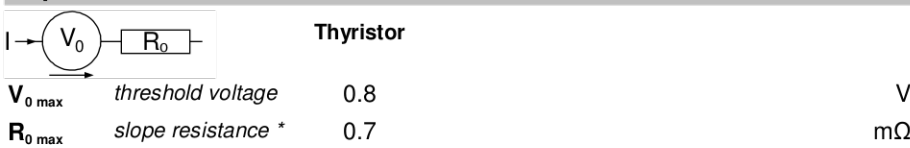

Outlines Y4

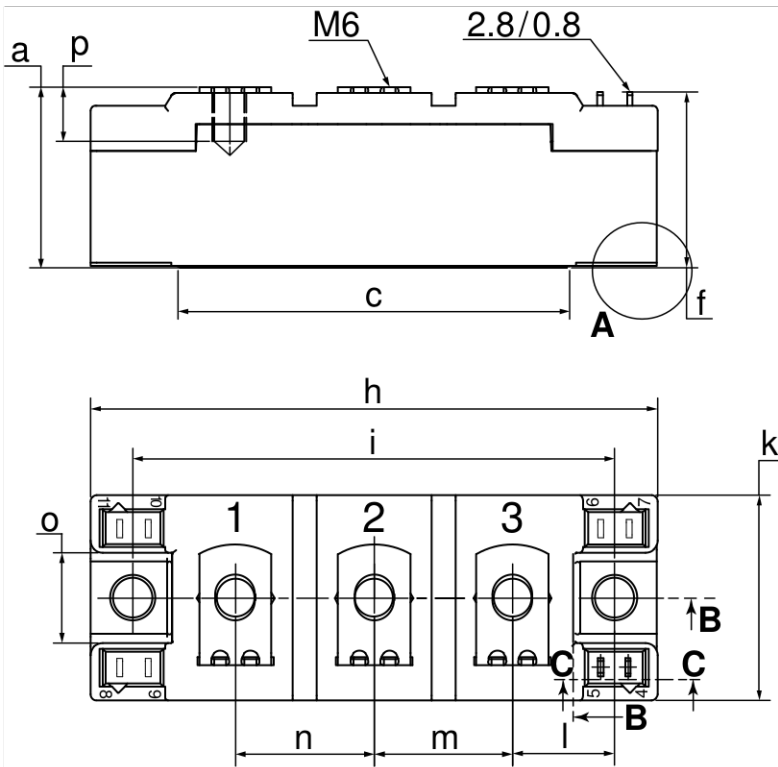

Dim.	MIN [mm]	MIN [mm]	MIN [inch]	MIN [inch]
a	30.0	30.6	1.181	1.205
b	typ. 0.25		typ. 0.010	
c	64.0	65.0	2.520	2.559
d	6.5	7.0	0.256	0.275
e	4.9	5.1	0.193	0.201
f	28.6	29.2	1.126	1.150
g	7.3	7.7	0.287	0.303
h	93.5	94.5	3.681	3.720
i	79.5	80.5	3.130	3.169
j	4.8	5.2	0.189	0.205
k	33.4	34.0	1.315	1.339
l	16.7	17.3	0.657	0.681
m	22.7	23.3	0.894	0.917
n	22.7	23.3	0.894	0.917
o	14.0	15.0	0.551	0.591
p	typ. 10.5		typ. 0.413	
r	1.8	2.4	0.071	0.041

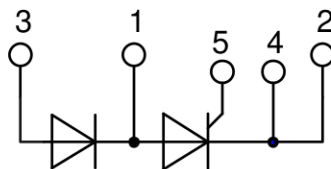
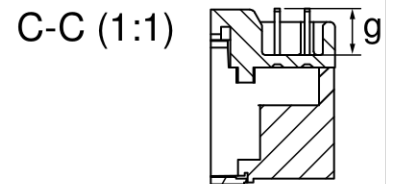
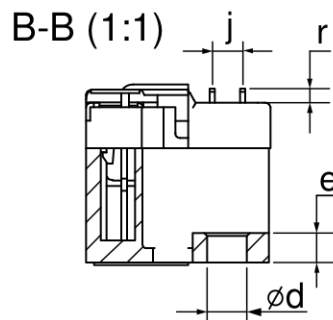
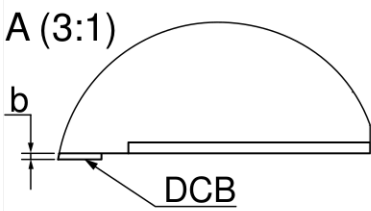

Thyristor

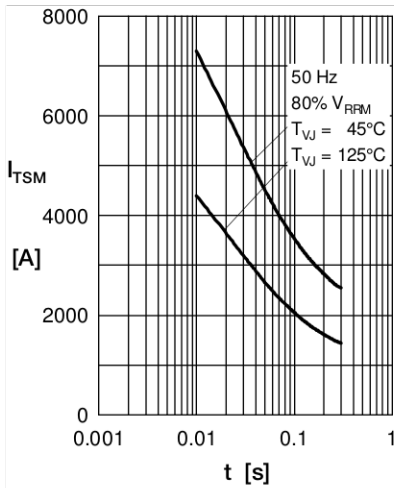

Fig. 1 Surge overload current I_{TSM} , I_{FSM} : Crest value, t: duration

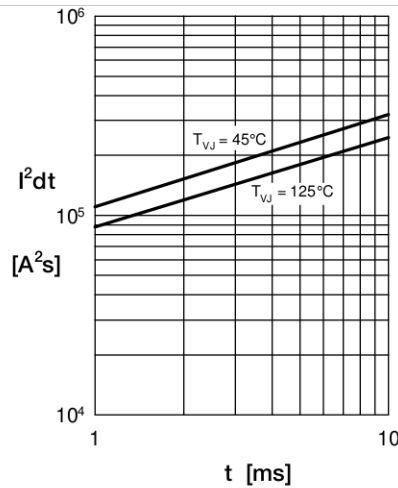

Fig. 2 I^2t versus time (1-10 ms)

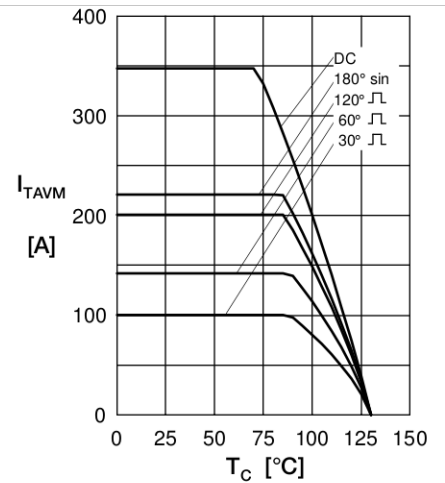

Fig. 3 Max. forward current at case temperature

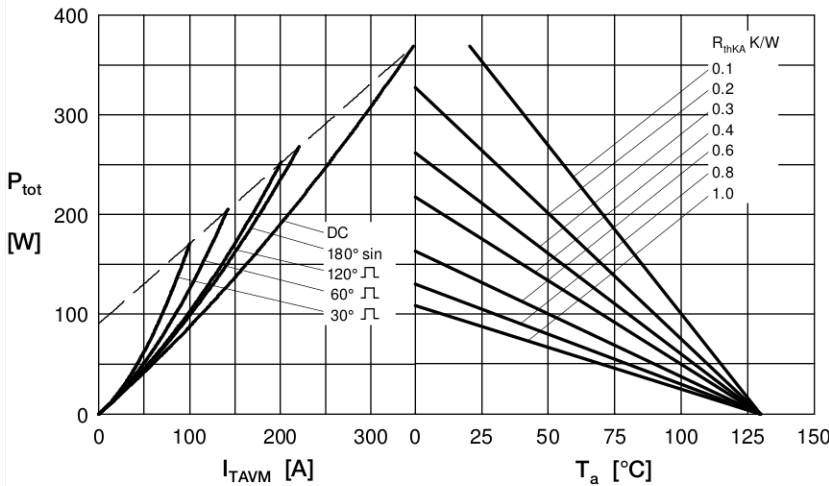

Fig. 4 Power dissipation vs. on-state current & ambient temperature (per thyristor or diode)

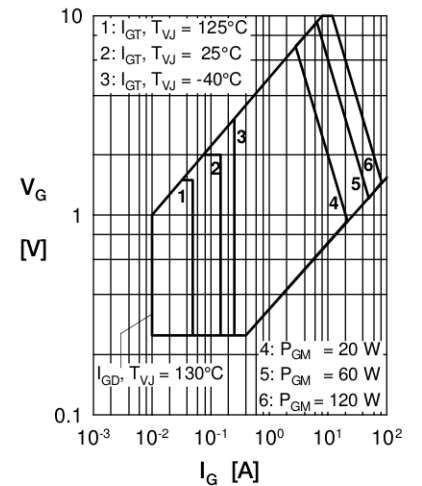

Fig. 5 Gate trigger characteristics

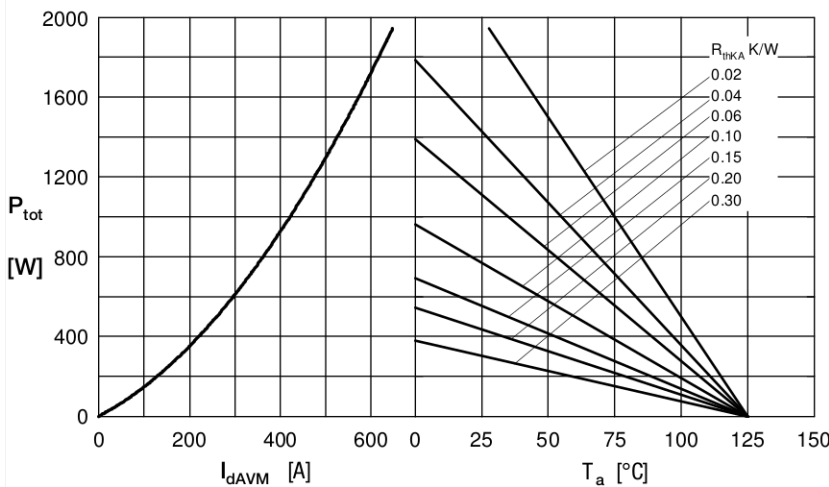

Fig. 6 Three phase rectifier bridge: Power dissipation versus direct output current and ambient temperature

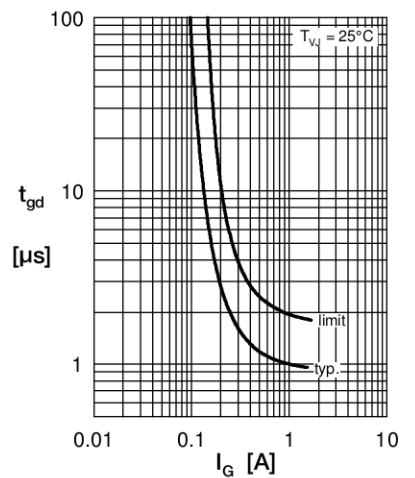

Fig. 7 Gate trigger delay time

Rectifier

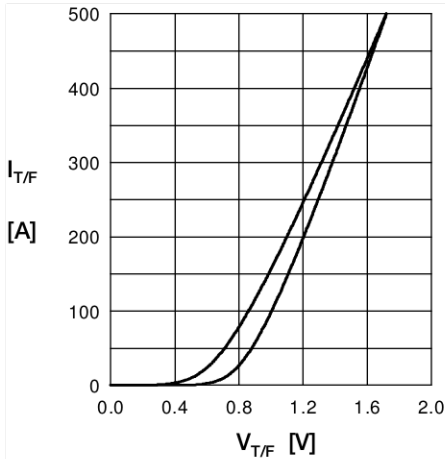
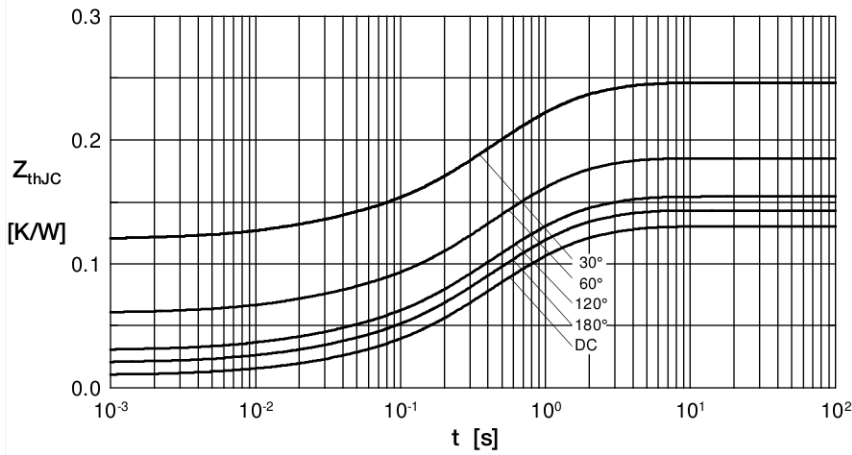

Fig. 8 Forward current versus voltage drop



Constants for Z_{thJC} calculation:

i	R_{thi} [K/W]	t_i [s]
1	0.0100	0.00014
2	0.0065	0.019
3	0.0250	0.180
4	0.0615	0.520
5	0.0270	1.600

Fig. 9 Transient thermal impedance junction to case at various conduction angles

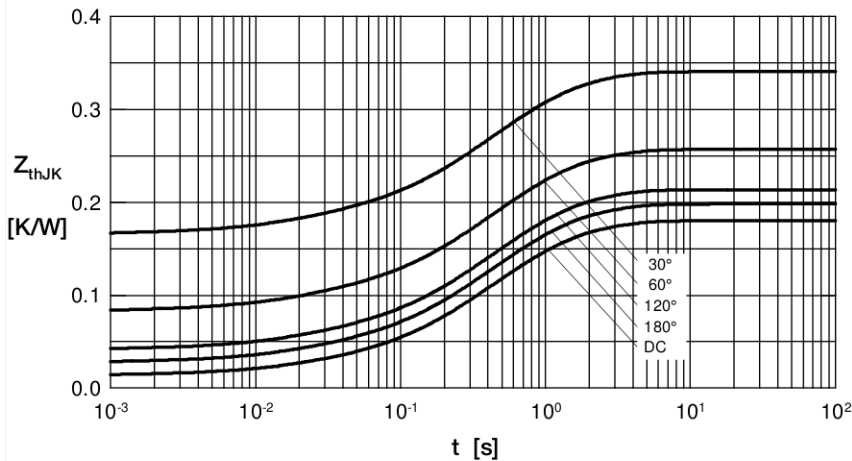

Fig. 10 Transient thermal impedance junction to heatsink (per thyristor/diode)