

# MEGAVAL® BLADE TYPE FUSE

MegaVAL® fuses are compliant with ISO 8820-5 Standard, recommended for the protection of heavy cross-section wires with heavy current duty. MegaVAL® are made of Zinc alloy (100 ÷ 250 A) and Copper (500 A), to optimize the performance to the nominal current.



**Breaking capacity:** 2000[A]  
**Voltage rating:** 32[Vdc]  
**Ambient Temperature:** -40°C to +125°C

MTA/ISO MegaVAL® operating time limits		
% In	min [s]	max [s]
1,00	14400 <sup>(a)</sup>	-
1,35	120 <sup>(a)</sup>	1800 <sup>(a)</sup>
2,00	1	15
3,50	0,3 <sup>(b)</sup>	5
6,00	0,1 <sup>(a)</sup>	1 <sup>(a)</sup>

<sup>(a)</sup> Not applicable for 500 A. <sup>(b)</sup> 0,5 for 500 A

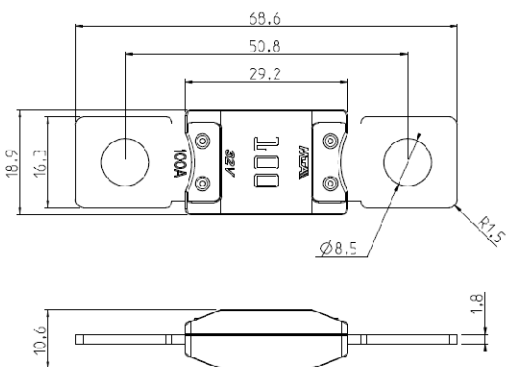

**MegaVAL® Operating Time @ 23°C test module ISO**

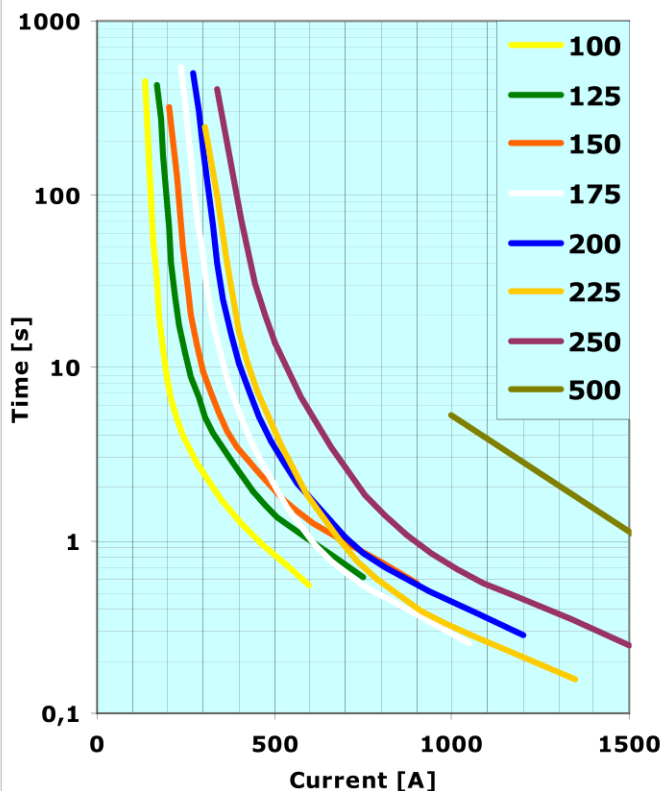

**MegaVAL® Re-Rating Curve. Test module ISO**

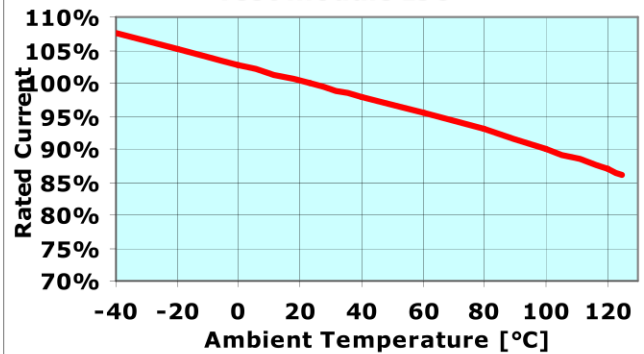

CURRENT RATING [A]	VOLTAGE DROP @ current rating [mV]	CABLE SIZE [mm <sup>2</sup> ]	I <sup>2</sup> t
100	86	16	219583
125	85		353125
150	93	25	463167
175	80		303521
200	81	35	416250
225	100		296042
250	80	50	637500
500	80	70	n.d