



# STFW4N150 STP4N150, STW4N150

N-channel 1500 V, 5  $\Omega$ , 4 A, PowerMESH™ Power MOSFET  
in TO-220, TO-247, TO-3PF

## Features

| Type      | V <sub>DSS</sub> | R <sub>DS(on)</sub> max | I <sub>D</sub> | P <sub>w</sub> |
|-----------|------------------|-------------------------|----------------|----------------|
| STFW4N150 | 1500 V           | < 7 $\Omega$            | 4 A            | 63 W           |
| STP4N150  | 1500 V           | < 7 $\Omega$            | 4 A            | 160 W          |
| STW4N150  | 1500 V           | < 7 $\Omega$            | 4 A            | 160 W          |

- 100% avalanche tested
- Intrinsic capacitances and Q<sub>g</sub> minimized
- High speed switching
- Fully isolated TO-3PF plastic packages
- Creepage distance path is 5.4 mm (typ.) for TO-3PF

## Application

- Switching applications

## Description

Using the well consolidated high voltage MESH OVERLAY™ process, STMicroelectronics has designed an advanced family of very high voltage Power MOSFETs with outstanding performances. The strengthened layout coupled with the company's proprietary edge termination structure, gives the lowest R<sub>DS(on)</sub> per area, unrivalled gate charge and switching characteristics.

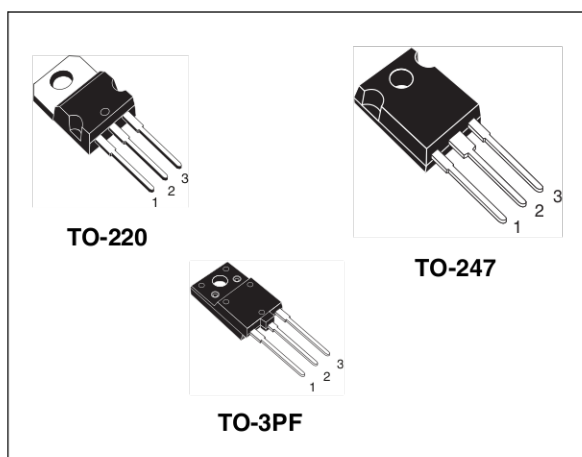

Figure 1. Internal schematic diagram.

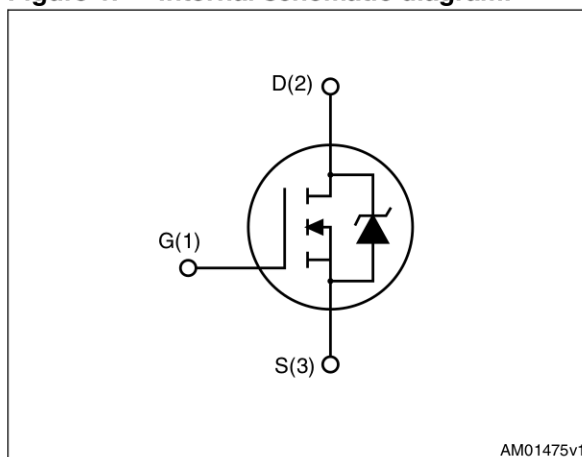

Table 1. Device summary

| Order codes | Marking | Package | Packaging |
|-------------|---------|---------|-----------|
| STFW4N150   | 4N150   | TO-3PF  | Tube      |
| STP4N150    | P4N150  | TO-220  | Tube      |
| STW4N150    | W4N150  | TO-247  | Tube      |

# Contents

|          |   |           |
|----------|---|-----------|
| <b>1</b> | <b>Electrical ratings</b> .....           | <b>3</b>  |
| <b>2</b> | <b>Electrical characteristics</b> .....   | <b>4</b>  |
| 2.1      | Electrical characteristics (curves) ..... | 6         |
| <b>3</b> | <b>Test circuits</b> .....                | <b>9</b>  |
| <b>4</b> | <b>Package mechanical data</b> .....      | <b>10</b> |
| <b>5</b> | <b>Revision history</b> .....             | <b>14</b> |

# 1 Electrical ratings

**Table 2. Absolute maximum ratings**

| Symbol         | Parameter  | Value      |        |                    | Unit             |
|----------------|--|------------|--------|--------------------|------------------|
|                |  | TO-220     | TO-247 | TO-3PF             |                  |
| $V_{DS}$       | Drain-source voltage ( $V_{GS} = 0$ )  | 1500       |        |                    | V                |
| $V_{GS}$       | Gate- source voltage   | $\pm 30$   |        |                    | V                |
| $I_D$          | Drain current (continuous) at $T_C = 25\text{ }^\circ\text{C}$   | 4          | 4      | 4 <sup>(1)</sup>   | A                |
| $I_D$          | Drain current (continuous) at $T_C = 100\text{ }^\circ\text{C}$  | 2.5        | 2.5    | 2.5 <sup>(1)</sup> | A                |
| $I_{DM}^{(1)}$ | Drain current (pulsed)   | 12         | 12     | 12 <sup>(1)</sup>  | A                |
| $P_{TOT}$      | Total dissipation at $T_C = 25\text{ }^\circ\text{C}$  | 160        |        | 63                 | W                |
| $V_{ISO}$      | Insulation withstand voltage (RMS) from all three leads to external heat sink ( $t=1\text{ s}; T_C=25\text{ }^\circ\text{C}$ ) |            |        | 3500               | V                |
| $T_{stg}$      | Storage temperature  | -55 to 150 |        |                    | $^\circ\text{C}$ |
| $T_j$          | Max. operating junction temperature  | 150        |        |                    | $^\circ\text{C}$ |

1. Pulse width limited by safe operating area

**Table 3. Thermal data**

| Symbol         | Parameter                               | Value  |        |        | Unit                      |
|----------------|---|--------|--------|--------|---------------------------|
|                |   | TO-220 | TO-247 | TO-3PF |                           |
| $R_{thj-case}$ | Thermal resistance junction-case max    | 0.78   |        | 2      | $^\circ\text{C}/\text{W}$ |
| $R_{thj-amb}$  | Thermal resistance junction-ambient max | 62.5   | 50     |        | $^\circ\text{C}/\text{W}$ |

**Table 4. Avalanche characteristics**

| Symbol   | Parameter  | Value | Unit |
|----------|--|-------|------|
| $I_{AR}$ | Avalanche current, repetitive or not-repetitive (pulse width limited by $T_j$ max)                                   | 4     | A    |
| $E_{AS}$ | Single pulse avalanche energy (starting $T_j = 25\text{ }^\circ\text{C}$ , $I_D = I_{AR}$ , $V_{DD} = 50\text{ V}$ ) | 350   | mJ   |

## 2 Electrical characteristics

( $T_{CASE} = 25\text{ °C}$  unless otherwise specified)

**Table 5. On/off states**

| Symbol        | Parameter   | Test conditions  | Min. | Typ. | Max.      | Unit                           |
|---------------|---|--|------|------|-----------|--------------------------------|
| $V_{(BR)DSS}$ | Drain-source<br>Breakdown voltage                   | $I_D = 1\text{ mA}$ , $V_{GS} = 0$   | 1500 |      |           | V                              |
| $I_{DSS}$     | Zero gate voltage<br>Drain current ( $V_{GS} = 0$ ) | $V_{DS} = \text{Max rating}$<br>$V_{DS} = \text{Max rating}$ , $T_C = 125\text{ °C}$ |      |      | 10<br>500 | $\mu\text{A}$<br>$\mu\text{A}$ |
| $I_{GSS}$     | Gate-body leakage<br>current ( $V_{DS} = 0$ )       | $V_{GS} = \pm 30\text{ V}$   |      |      | $\pm 100$ | nA                             |
| $V_{GS(th)}$  | Gate threshold voltage                              | $V_{DS} = V_{GS}$ , $I_D = 250\text{ }\mu\text{A}$                                   | 3    | 4    | 5         | V                              |
| $R_{DS(on)}$  | Static drain-source on<br>resistance                | $V_{GS} = 10\text{ V}$ , $I_D = 2\text{ A}$  |      | 5    | 7         | $\Omega$                       |

**Table 6. Dynamic**

| Symbol         | Parameter                       | Test conditions  | Min. | Typ. | Max. | Unit |
|----------------|---------------------------------|--|------|------|------|------|
| $g_{fs}^{(1)}$ | Forward transconductance        | $V_{DS} = 30\text{ V}$ , $I_D = 2\text{ A}$  | -    | 3.5  |      | S    |
| $C_{iss}$      | Input capacitance               | $V_{DS} = 25\text{ V}$ , $f = 1\text{ MHz}$ ,<br>$V_{GS} = 0$  | -    | 1300 |      | pF   |
| $C_{oss}$      | Output capacitance              |  |      | 120  |      | pF   |
| $C_{rss}$      | Reverse transfer<br>capacitance |  |      | 12   |      | pF   |
| $t_{d(on)}$    | Turn-on delay time              | $V_{DD} = 750\text{ V}$ , $I_D = 2\text{ A}$ ,<br>$R_G = 4.7\text{ }\Omega$ , $V_{GS} = 10\text{ V}$<br><i>Figure 19</i> | -    | 35   |      | ns   |
| $T_r$          | Rise time                       |  |      | 30   |      | ns   |
| $t_{d(off)}$   | Turn-off delay time             |  |      | 45   |      | ns   |
| $t_f$          | Fall time                       |  |      | 45   |      | ns   |
| $Q_g$          | Total gate charge               | $V_{DD} = 600\text{ V}$ , $I_D = 4\text{ A}$ ,<br>$V_{GS} = 10\text{ V}$<br><i>Figure 20</i>                             | -    | 30   | 50   | nC   |
| $Q_{gs}$       | Gate-source charge              |  |      | 10   |      | nC   |
| $Q_{gd}$       | Gate-drain charge               |  |      | 9    |      | nC   |

1. Pulsed: pulse duration=300  $\mu\text{s}$ , duty cycle 1.5%

Table 7. Source drain diode

| Symbol          | Parameter                     | Test conditions  | Min. | Typ. | Max. | Unit          |
|-----------------|-------------------------------|--|------|------|------|---------------|
| $I_{SD}$        | Source-drain current          |  | -    |      | 4    | A             |
| $I_{SDM}^{(1)}$ | Source-drain current (pulsed) |  | -    |      | 12   | A             |
| $V_{SD}^{(2)}$  | Forward on voltage            | $I_{SD} = 4 \text{ A}, V_{GS} = 0$   | -    |      | 2    | V             |
| $t_{rr}$        | Reverse recovery time         | $I_{SD} = 4 \text{ A},$<br>$di/dt = 100 \text{ A}/\mu\text{s}$<br>$V_{DD} = 45 \text{ V}$<br><i>Figure 21</i>                          | -    | 510  |      | ns            |
| $Q_{rr}$        | Reverse recovery charge       |  |      | 3    |      | $\mu\text{C}$ |
| $I_{RRM}$       | Reverse recovery current      |  |      | 12   |      | A             |
| $t_{rr}$        | Reverse recovery time         | $I_{SD} = 4 \text{ A},$<br>$di/dt = 100 \text{ A}/\mu\text{s}$<br>$V_{DD} = 45 \text{ V}, T_j = 150^\circ\text{C}$<br><i>Figure 21</i> | -    | 615  |      | ns            |
| $Q_{rr}$        | Reverse recovery charge       |  |      | 4    |      | $\mu\text{C}$ |
| $I_{RRM}$       | Reverse recovery current      |  |      | 12.6 |      | A             |

1. Pulse width limited by safe operating area
2. Pulsed: pulse duration=300 $\mu\text{s}$ , duty cycle 1.5%

## 2.1 Electrical characteristics (curves)

Figure 2. Safe operating area for TO-220

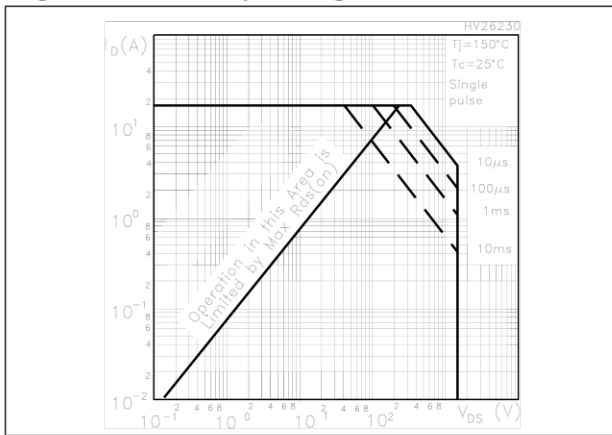

Figure 3. Thermal impedance for TO-220

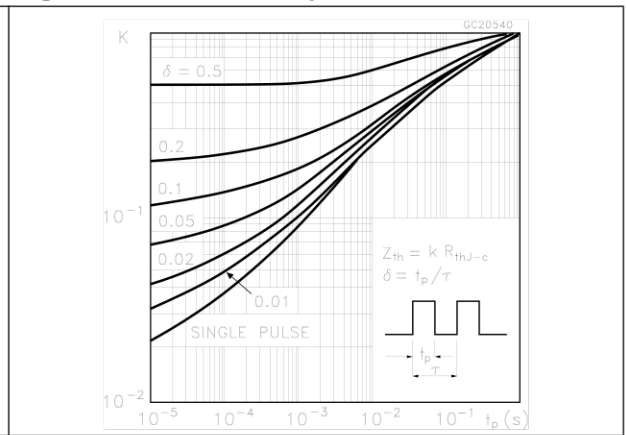

Figure 4. Safe operating area for TO-3PF

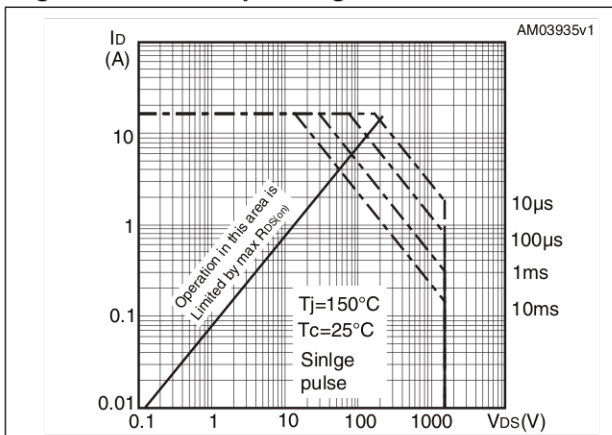

Figure 5. Thermal impedance for TO-3PF

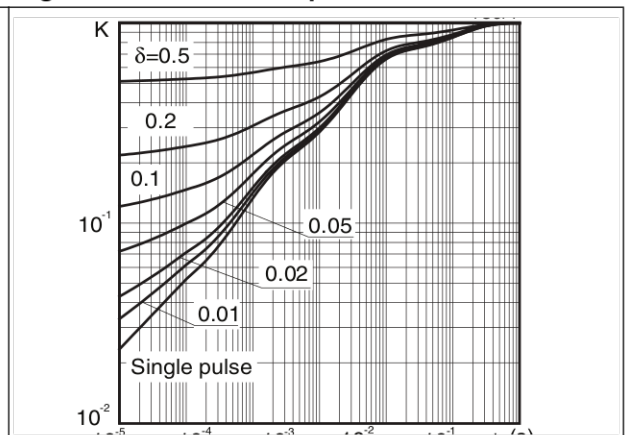

Figure 6. Safe operating area for TO-247

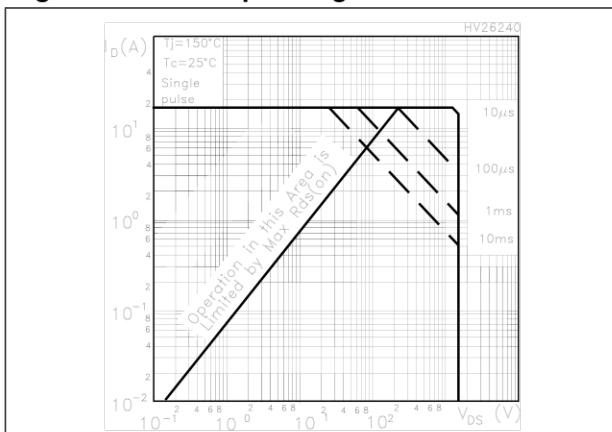

Figure 7. Thermal impedance for TO-247

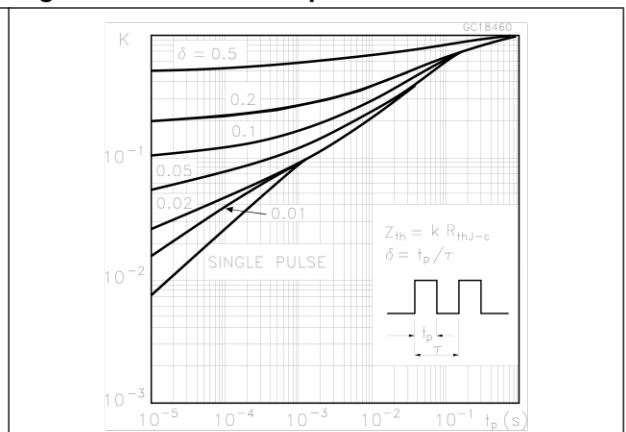

Figure 8. Output characteristics

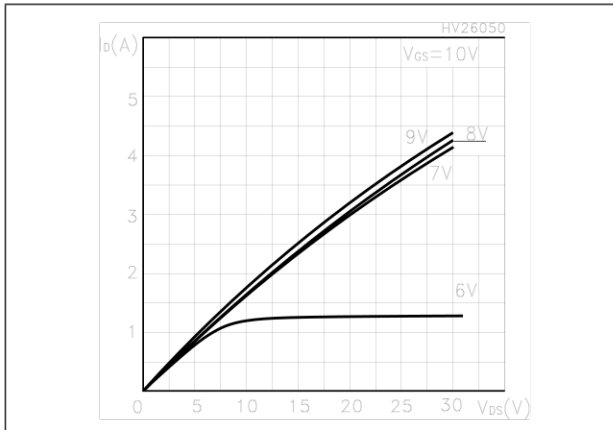

Figure 9. Transfer characteristics

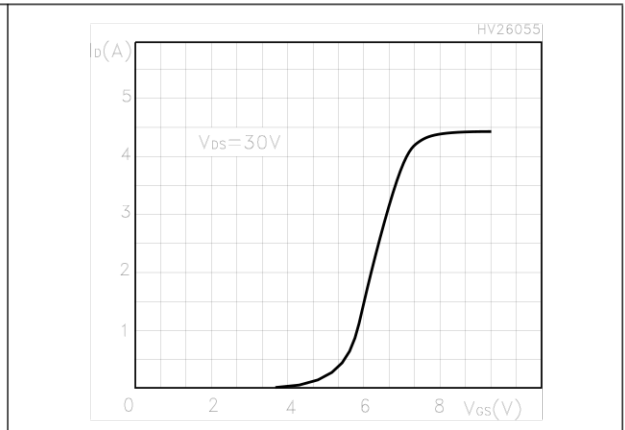

Figure 10. Transconductance

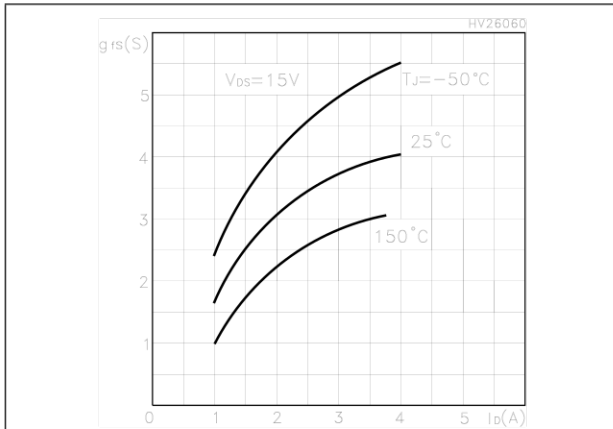

Figure 11. Static drain-source on resistance

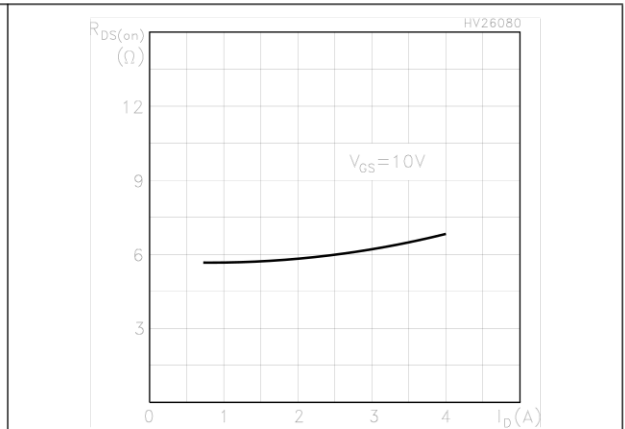

Figure 12. Gate charge vs gate-source voltage Figure 13. Capacitance variations

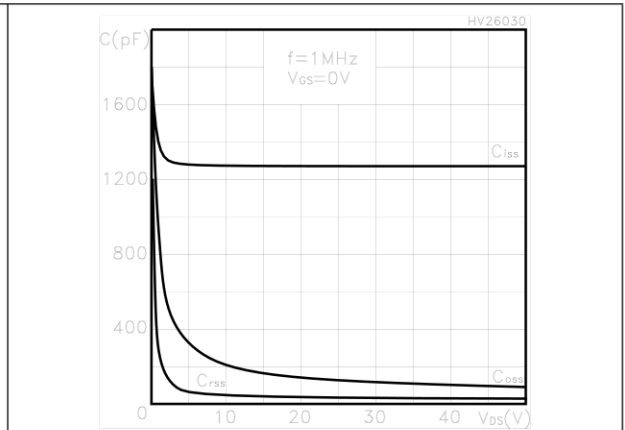
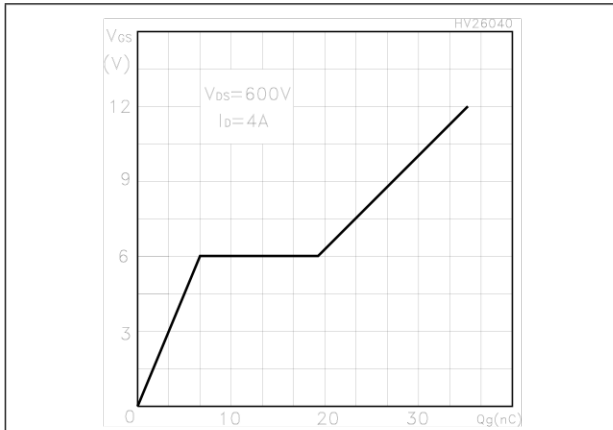

Figure 14. Normalized gate threshold voltage vs temperature

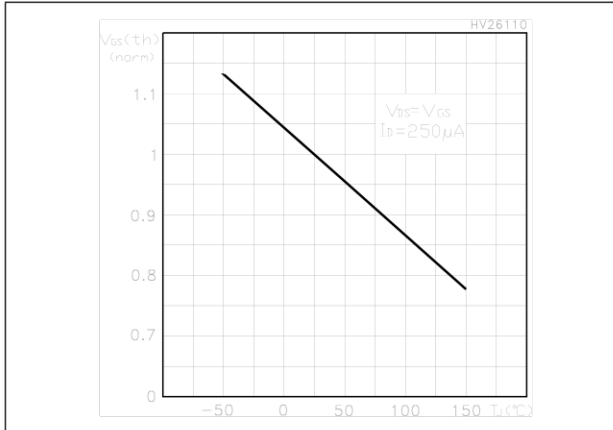

Figure 15. Normalized on resistance vs temperature

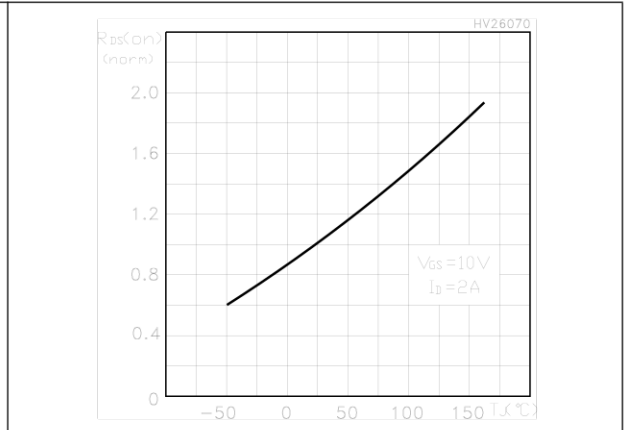

Figure 16. Source-drain diode forward characteristics

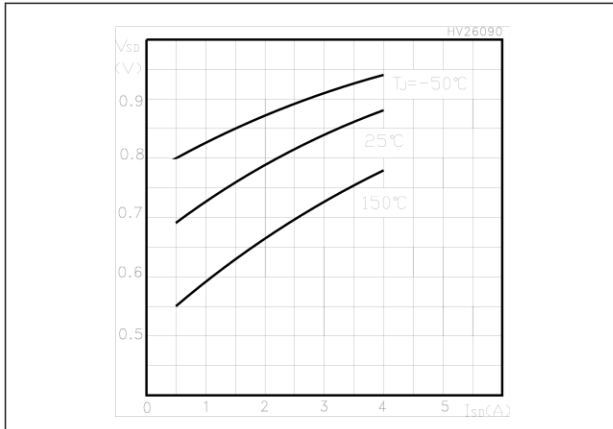

Figure 17. Normalized BV<sub>DSS</sub> vs temperature

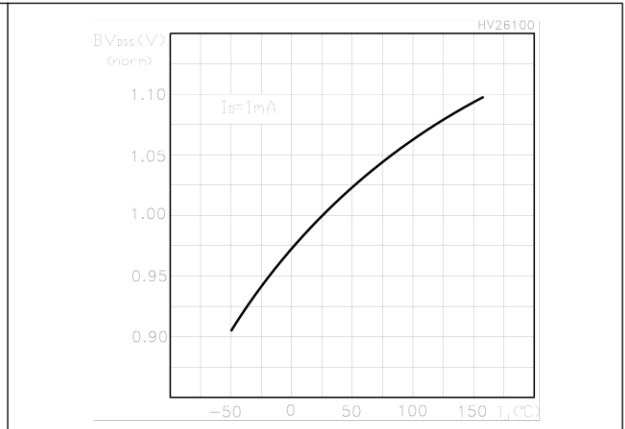
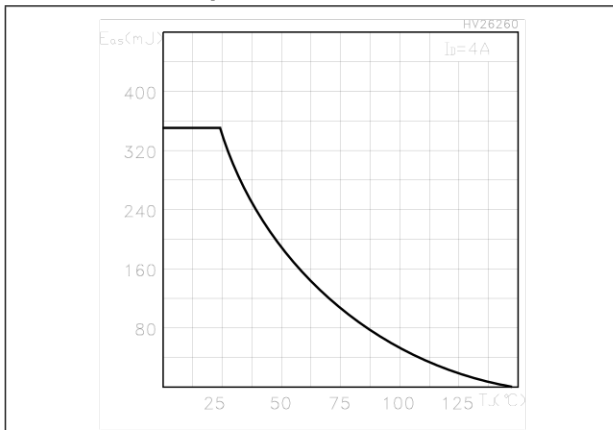

Figure 18. Maximum avalanche energy vs temperature





### 3 Test circuits

**Figure 19. Switching times test circuit for resistive load**

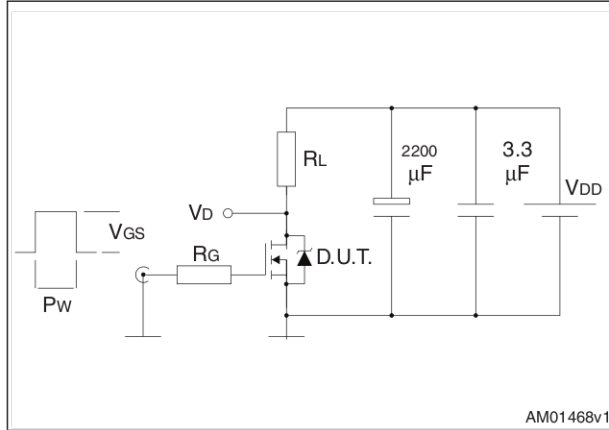

**Figure 20. Gate charge test circuit**

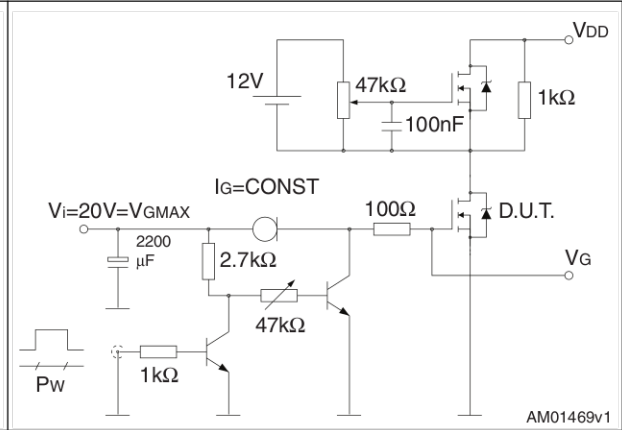

**Figure 21. Test circuit for inductive load switching and diode recovery times**

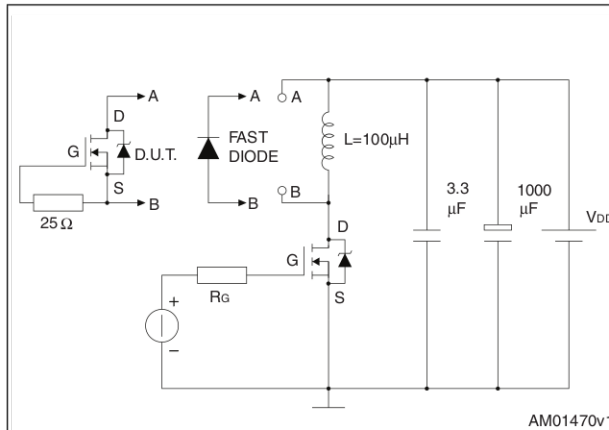

**Figure 22. Unclamped inductive load test circuit**

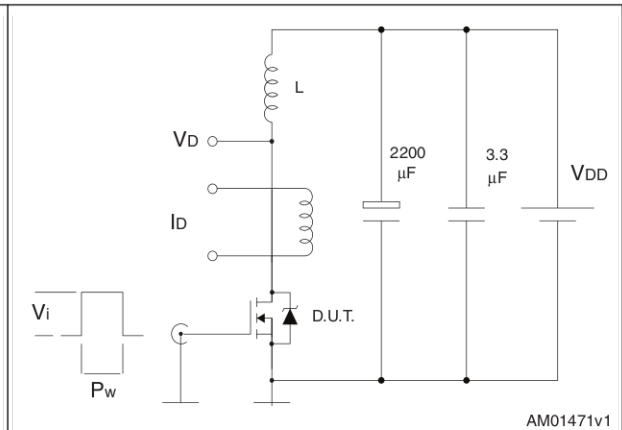

**Figure 23. Unclamped inductive waveform**

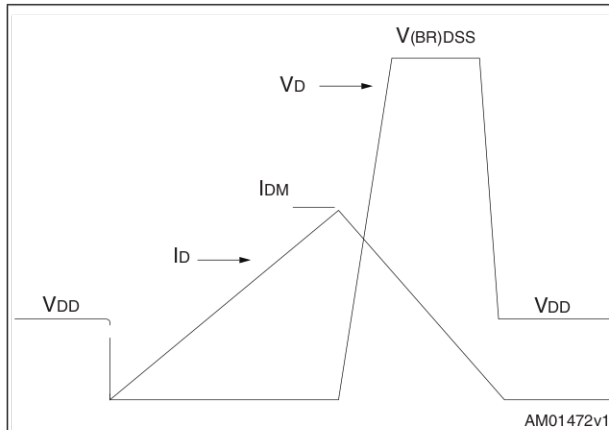

**Figure 24. Switching time waveform**

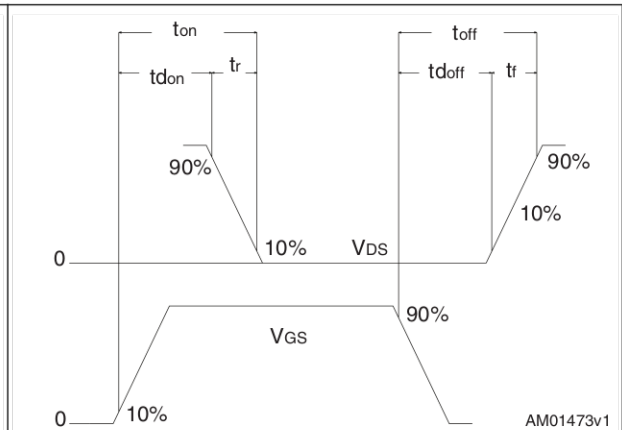

## 4 Package mechanical data

In order to meet environmental requirements, ST offers these devices in different grades of ECOPACK® packages, depending on their level of environmental compliance. ECOPACK® specifications, grade definitions and product status are available at: [www.st.com](http://www.st.com). ECOPACK is an ST trademark.

TO-220 mechanical data

| Dim | mm    |       |       | inch  |       |       |
|-----|-------|-------|-------|-------|-------|-------|
|     | Min   | Typ   | Max   | Min   | Typ   | Max   |
| A   | 4.40  |       | 4.60  | 0.173 |       | 0.181 |
| b   | 0.61  |       | 0.88  | 0.024 |       | 0.034 |
| b1  | 1.14  |       | 1.70  | 0.044 |       | 0.066 |
| c   | 0.48  |       | 0.70  | 0.019 |       | 0.027 |
| D   | 15.25 |       | 15.75 | 0.6   |       | 0.62  |
| D1  |       | 1.27  |       |       | 0.050 |       |
| E   | 10    |       | 10.40 | 0.393 |       | 0.409 |
| e   | 2.40  |       | 2.70  | 0.094 |       | 0.106 |
| e1  | 4.95  |       | 5.15  | 0.194 |       | 0.202 |
| F   | 1.23  |       | 1.32  | 0.048 |       | 0.051 |
| H1  | 6.20  |       | 6.60  | 0.244 |       | 0.256 |
| J1  | 2.40  |       | 2.72  | 0.094 |       | 0.107 |
| L   | 13    |       | 14    | 0.511 |       | 0.551 |
| L1  | 3.50  |       | 3.93  | 0.137 |       | 0.154 |
| L20 |       | 16.40 |       |       | 0.645 |       |
| L30 |       | 28.90 |       |       | 1.137 |       |
| ∅P  | 3.75  |       | 3.85  | 0.147 |       | 0.151 |
| Q   | 2.65  |       | 2.95  | 0.104 |       | 0.116 |

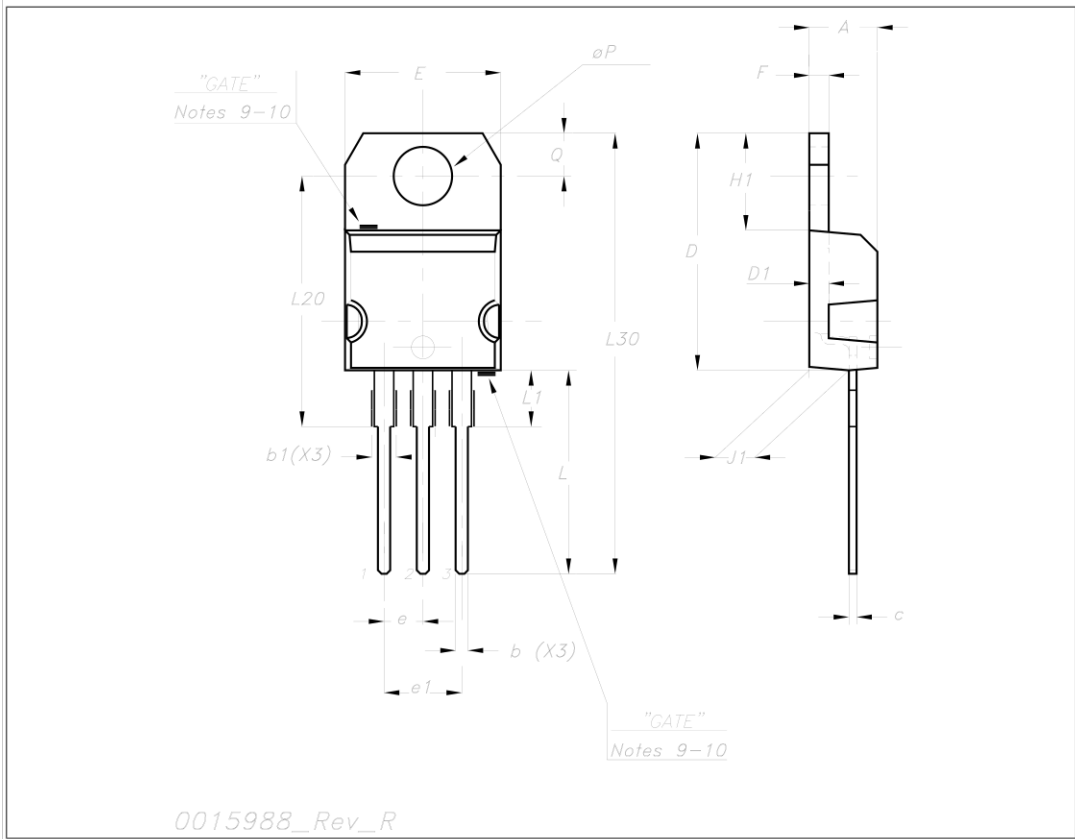

**TO-247 Mechanical data**

| Dim. | mm.   |       |       |
|------|-------|-------|-------|
|      | Min.  | Typ   | Max.  |
| A    | 4.85  |       | 5.15  |
| A1   | 2.20  |       | 2.60  |
| b    | 1.0   |       | 1.40  |
| b1   | 2.0   |       | 2.40  |
| b2   | 3.0   |       | 3.40  |
| c    | 0.40  |       | 0.80  |
| D    | 19.85 |       | 20.15 |
| E    | 15.45 |       | 15.75 |
| e    |       | 5.45  |       |
| L    | 14.20 |       | 14.80 |
| L1   | 3.70  |       | 4.30  |
| L2   |       | 18.50 |       |
| øP   | 3.55  |       | 3.65  |
| øR   | 4.50  |       | 5.50  |
| S    |       | 5.50  |       |

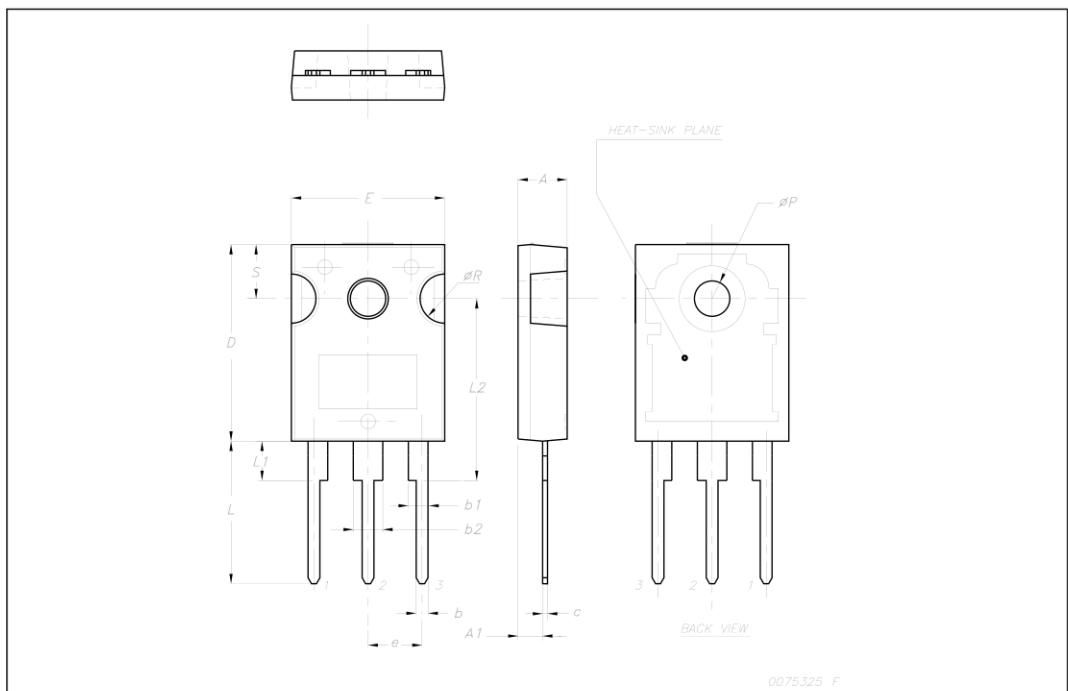

**TO-3PF mechanical data**

| DIM. | mm.   |      |       |
|------|-------|------|-------|
|      | min.  | typ  | max.  |
| A    | 5.30  |      | 5.70  |
| C    | 2.80  |      | 3.20  |
| D    | 3.10  |      | 3.50  |
| D1   | 1.80  |      | 2.20  |
| E    | 0.80  |      | 1.10  |
| F    | 0.65  |      | 0.95  |
| F2   | 1.80  |      | 2.20  |
| G    | 10.30 |      | 11.50 |
| G1   |       | 5.45 |       |
| H    | 15.30 |      | 15.70 |
| L    | 9.80  | 10   | 10.20 |
| L2   | 22.80 |      | 23.20 |
| L3   | 26.30 |      | 26.70 |
| L4   | 43.20 |      | 44.40 |
| L5   | 4.30  |      | 4.70  |
| L6   | 24.30 |      | 24.70 |
| L7   | 14.60 |      | 15    |
| N    | 1.80  |      | 2.20  |
| R    | 3.80  |      | 4.20  |
| Dia  | 3.40  |      | 3.80  |

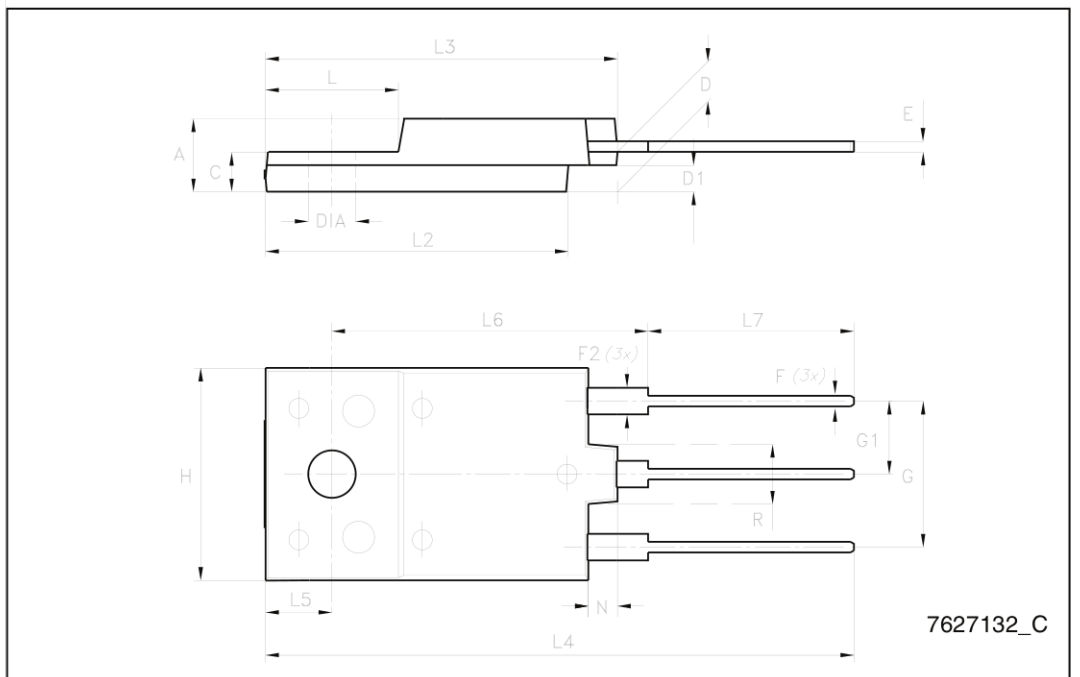

## 5 Revision history

**Table 8. Document revision history**

| Date        | Revision | Changes  |
|-------------|----------|--|
| 29-Mar-2005 | 1        | Initial release  |
| 07-Jul-2005 | 2        | Removed TO-220FP   |
| 07-Oct-2005 | 3        | Document status promoted from preliminary data to datasheet  |
| 10-Aug-2006 | 4        | Document reformatted, no content change  |
| 06-Nov-2007 | 5        | Updated unit on <a href="#">Table 5: On/off states</a>   |
| 09-Apr-2008 | 6        | Added new packages: TO-220FH, TO-3PF   |
| 21-Jan-2009 | 7        | Remove package TO-220FH  |
| 23-Feb-2009 | 8        | Added $P_{TOT}$ value for TO-3PF $P_{TOT}$ ( <a href="#">Table 2: Absolute maximum ratings</a> )                                       |
| 23-Jul-2009 | 9        | Added new figures: <a href="#">Figure 4: Safe operating area for TO-3PF</a> and <a href="#">Figure 5: Thermal impedance for TO-3PF</a> |

**Please Read Carefully:**

Information in this document is provided solely in connection with ST products. STMicroelectronics NV and its subsidiaries ("ST") reserve the right to make changes, corrections, modifications or improvements, to this document, and the products and services described herein at any time, without notice.

All ST products are sold pursuant to ST's terms and conditions of sale.

Purchasers are solely responsible for the choice, selection and use of the ST products and services described herein, and ST assumes no liability whatsoever relating to the choice, selection or use of the ST products and services described herein.

No license, express or implied, by estoppel or otherwise, to any intellectual property rights is granted under this document. If any part of this document refers to any third party products or services it shall not be deemed a license grant by ST for the use of such third party products or services, or any intellectual property contained therein or considered as a warranty covering the use in any manner whatsoever of such third party products or services or any intellectual property contained therein.

**UNLESS OTHERWISE SET FORTH IN ST'S TERMS AND CONDITIONS OF SALE ST DISCLAIMS ANY EXPRESS OR IMPLIED WARRANTY WITH RESPECT TO THE USE AND/OR SALE OF ST PRODUCTS INCLUDING WITHOUT LIMITATION IMPLIED WARRANTIES OF MERCHANTABILITY, FITNESS FOR A PARTICULAR PURPOSE (AND THEIR EQUIVALENTS UNDER THE LAWS OF ANY JURISDICTION), OR INFRINGEMENT OF ANY PATENT, COPYRIGHT OR OTHER INTELLECTUAL PROPERTY RIGHT.**

**UNLESS EXPRESSLY APPROVED IN WRITING BY AN AUTHORIZED ST REPRESENTATIVE, ST PRODUCTS ARE NOT RECOMMENDED, AUTHORIZED OR WARRANTED FOR USE IN MILITARY, AIR CRAFT, SPACE, LIFE SAVING, OR LIFE SUSTAINING APPLICATIONS, NOR IN PRODUCTS OR SYSTEMS WHERE FAILURE OR MALFUNCTION MAY RESULT IN PERSONAL INJURY, DEATH, OR SEVERE PROPERTY OR ENVIRONMENTAL DAMAGE. ST PRODUCTS WHICH ARE NOT SPECIFIED AS "AUTOMOTIVE GRADE" MAY ONLY BE USED IN AUTOMOTIVE APPLICATIONS AT USER'S OWN RISK.**

Resale of ST products with provisions different from the statements and/or technical features set forth in this document shall immediately void any warranty granted by ST for the ST product or service described herein and shall not create or extend in any manner whatsoever, any liability of ST.

ST and the ST logo are trademarks or registered trademarks of ST in various countries.

Information in this document supersedes and replaces all information previously supplied.

The ST logo is a registered trademark of STMicroelectronics. All other names are the property of their respective owners.

© 2009 STMicroelectronics - All rights reserved

STMicroelectronics group of companies

Australia - Belgium - Brazil - Canada - China - Czech Republic - Finland - France - Germany - Hong Kong - India - Israel - Italy - Japan - Malaysia - Malta - Morocco - Philippines - Singapore - Spain - Sweden - Switzerland - United Kingdom - United States of America

[www.st.com](http://www.st.com)